

BODY BUILDER INSTRUCTIONS

Mack Trucks



Electrical Wiring and Connections
PI, AN, GR
LR, TE
Section 3
(VECU5)

Introduction

This information provides design and function, specification and procedure details for Electrical Wiring and Connections for MACK vehicles.

Note: For information on *mDRIVE* PTO installation and wiring see Section 9 PTO Installation, *mDRIVE*.

Note: For information on PTO parameter programming, see Section 9 PTO Parameter Programming.

Unless stated otherwise, following a recommendation listed in this manual does not automatically guarantee compliance with applicable government regulations. Compliance with applicable government regulations is your responsibility as the party making the additions/modifications.

Please be advised that the Mack Trucks, Inc. vehicle warranty does not apply to any MACK vehicle that has been modified in any way, which in MACK's judgment might affect the vehicles stability or reliability.

Note: Vehicles built on or after January 1, 2021 will have VECU5.

Contents

- "Abbreviations", page 3
- "General Wiring Definitions", page 4
- "Fuses and Relay Center", page 6
- "Routing and Clipping Guidelines", page 14
- "Body Builder Connectors, Schematic Examples", page 26
- "Buffered Ground Speed Signal X156 / BB-OPT connector", page 29
- "Remote Start n Stop", page 35
- "Remote Engine Stop", page 37
- "Adding Auxiliary Accelerator Pedal", page 39
- "SIB Switch Instructions for Remote PTO Operation", page 40
- "BodyLink III", page 42

- “Auxiliary Switch Locations (Cab)”, page 47
- “Power Connections”, page 48
- “Body Builder Connections ”, page 52
- “RP170A Refuse Related Chassis to Body Interface Connectors”, page 66
- “LR Work brake”, page 70
- “Snow Plow with Extra Auxiliary Lamp”, page 72
- “Data Link System”, page 80
- “Vehicle Accessory Connector (Mack Conventional)”, page 83
- “Termination Resistor”, page 92
- “9-pin Diagnostic Connector”, page 94
- “16-pin Diagnostic Connector”, page 95
- “Multiplexing Body Builder DL5 J1939 CAN ”, page 105
- “Support Inbound and Outbound DL1 J-1939 Message Information ”, page 113
- “Road-Speed Reader Kit”, page 123
- “Sensata Technologies PreView System (Passive Safety System)”, page 128
- “Bendix® Wingman® Fusion™ 2.0 Advanced Driver Assistance System (Active safety system)”, page 143
- “Liftgate trailer connector usage recommendations”, page 149

Abbreviations

Acronym	Description
ACC	Adaptive Cruise Control
ACM	Aftertreatment Control Module
BBM	Body Builder Module
BOC	Back of Cab
CAN	Controller Area Network
CDS	Customer Defined Statement (replaced by DCL)
DCL	DataMax Control Language
ECC/MCC	Electronic Climate Control/ Manual Climate Control
ECM	Engine Control Module
ECS	Electronic Speed Control
EHT	Electronic Hand Throttle
EMS	Engine Management System
ESC	Engine Speed Control
FMI	Failure Mode Identifier
GMT	Greenwich Mean Time
GSECU	Gear Selector ECU
LCM	Light Control Module
MID	Message Identifier (J1587 source)
NOx	Nitrogen Oxide
PGN	Parameter Group Number (J1939)
PID	Parameter Identification (J1587)
PTO	Power take-off
PTT2	Premium Tech Tool 2
SA	Source Address (J1939 unit identifier)
SCU	Satellite Control Unit (Qualcomm)
SID	Subsystem Identification (J1587)
SPN	Suspect Parameter Number (J1939)
SRS	Supplementary restraint system
SSC	Single Speed Control
TCM	Transmission control unit
TPM	Tire Pressure Monitor
VDA	Vehicle Data Administration (OEM database)
VECU	Vehicle ECU
V-MAC	Vehicle Management and Control (Mack's electrical architecture)

General Wiring Definitions

The general wiring definitions provide a standardized list of terminology used in running wires, hoses and cables throughout the vehicle.

Abrasive Surface	Items capable of causing damage to the routed commodity in a rubbing condition during vehicle operation
AWG	American Wire Gauge
Bundled With	A number of items tied, wrapped or otherwise held together
Cable Tie	A nylon plastic self-sizing strap, UV resistant, capable of bundling specified load(s) during vehicle operation
Chafing	To wear away by rubbing
Contacts	Items touching each other.
Crimped	A routed commodity that is bent or pressed into ridges
Damaged	An item that differs from its original condition
Drooping	Routed items hanging downward, which are detrimental to safe vehicle operation
Dual Fall	(Pertaining to the Compressor Discharge Line) A high point in the routing of the Compressor Discharge Line (located on the engine) whereby any collected moisture is allowed to fall in two different directions where it is either dissipated by heat or is purged
High Current Electrical Cables	Wire sizes 13 mm sq. (0.5 inches sq.) (6 AWG) and larger
High Nut	Extended clamp length
Kinked	A tight bend, curl or twist in the routed commodity causing flow to be restricted
Low Current Electrical Cables	Wire sizes 8 mm sq. (0.3-inches sq) (8 AWG) and smaller
Low Nut	Standard clamp length
Material Grade 30	Minimum yield strength of 30,000 psi
Material Grade 50	Minimum yield strength of 50,000 psi
May	Verb typically used in a statement of practice that is a permissive condition and carries no requirement or recommendation. It can be included to alter statements of mandate or recommendation
Not Secured	Items not fastened, bundled or tied
Plastic Conduit	Corrugated or smooth wall tubing used to protect hoses, harnesses, cables, tubing, pipes, etc.
Puncture	Small hole or wound
Routed With	Items taking the same path but not attached to each other (i.e., parallel but separate)
Rubbing	Items that contact each other and have independent movement
Shall	Verb typically used in a statement of required, mandatory or specifically prohibitive practice regarding routing and clipping
Sharp Edge	A surface capable of cutting or piercing the routed commodity during vehicle operation
Should	Verb typically used in a statement of recommended, but not mandatory, practice in typical situations with deviations allowed if Engineering judgment or Engineering study indicates that the deviation is appropriate

Twisted	Distorted from the routed commodities' original shape about it's cross-sectional centerline
Touch	Items that contact each other but do not have relative movement

Fuses and Relay Center

AN, GR and PI

The truck's fuses and relays are located under the cover in the center of the instrument panel.

There are decals under the cover which notes the location of the fuses and relays. Also, the purpose of each fuse and relay is detailed.

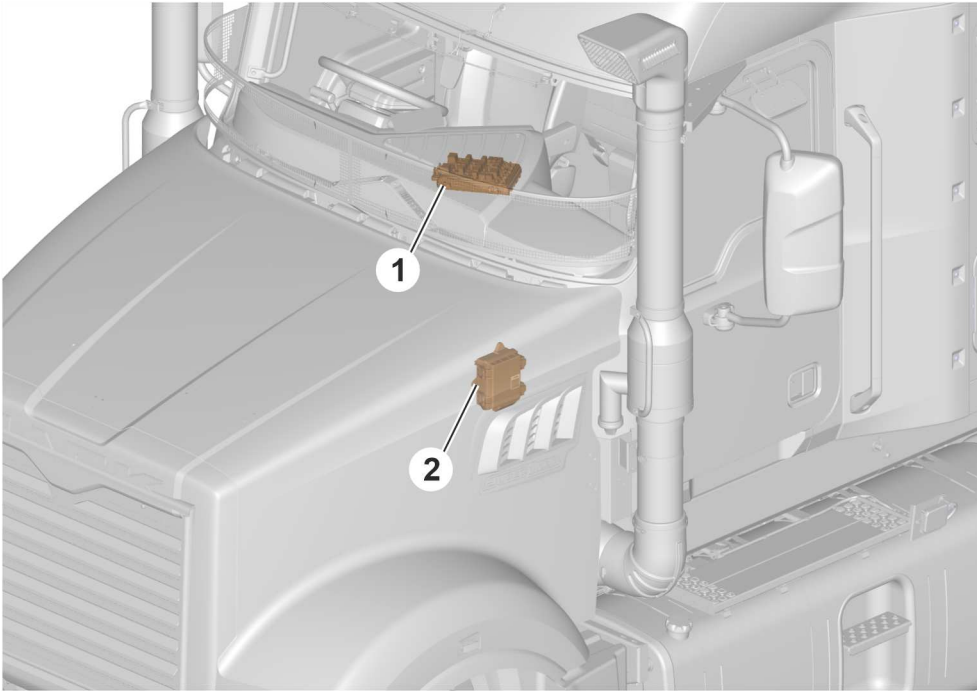

T3200621

1. FRC (Fuse and Relay Centre)
2. EFRC (External Fuse and Relay Center)

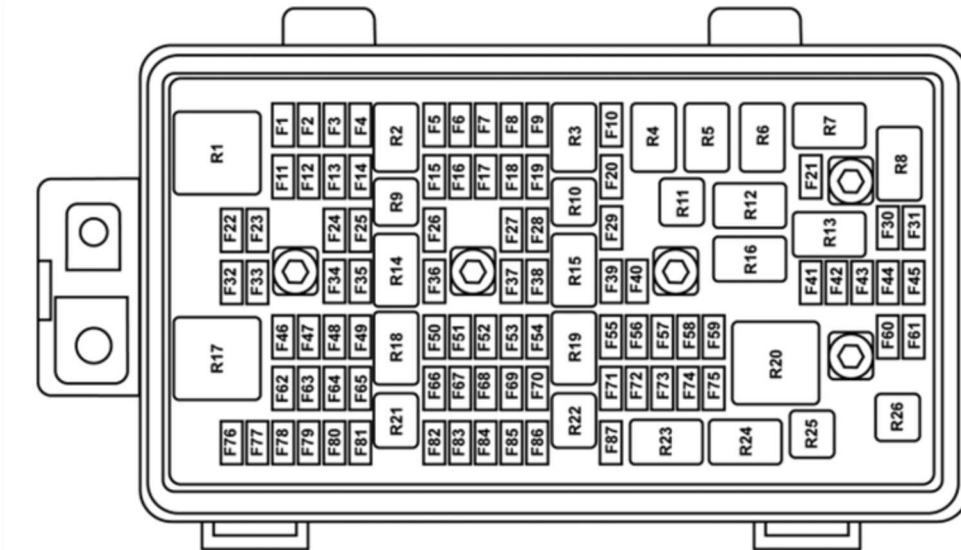

T3200622

**FUSE & RELAY CENTER CONSOLE MOUNTED
MINI FUSES**

BUSS	"F" FUSE POSITION	FUSE RATING STD & OPT	DESCRIPTION
ACC	1	20	OPEN
ACC	2	10	HVAC
ACC	3	20	DRIVER HEATED SEAT / COOLER
ACC	3	25	DRIVER & PASSENGER HEATED SEATS
ACC	4	10	RADIO
ACC	4	25	RADIO WITH AMPLIFIER
LVD	5	30	LECM4
LVD	6	20	RH SLEEPER PWR PORTS/ CONSOLE
LVD	7	20	LH SLEEPER POWER PORTS
LVD	8	15	AUX SWITCH 1
LVD	9	10	USB CHARGE PORTS
LVD	10	20	CUSTOMER LVD2
ACC	11	10	INTERIOR AUX FAN
ACC	12	20	DASH POWER PORT
ACC	13	20	OPEN
ACC	14	10	OPEN
LVD	15	30	LECM1/BBM
LVD	16	20	TMP RP 1226
LVD	17	15	AUX SWITCH 6
LVD	18	30	LECM3 HVAC FAN
LVD	18	10	48 INCH SLEEPER
LVD	19	30	NEUTRAL POWER
BATT	20	10	HORN
INLINE	21	5	OPEN
LVD	22	20	DCP R
IGN	23	15	CUSTOMER / AUX SW
LVD	24	20	DCP L
ACC	25	5	DCP
LVD	26	10	DOME/DOOR INTERIOR LAMPS
BATT	27	20	LCM3
LVD	28	20	CUSTOMER LVD1
IGN+	29	5	EFRC
IGNSW	30	5	ULTRASHIFT
IGNSW	31	5	CUMMINS IGNITION

IGN	32	15	CUSTOMER IGN1/AUX SW
IGN	33	10	CLU/AIR SOL/SW
IGN	34	10	TMP RP1226
IGN	35	15	AUX SW 5
IGN	36	5	TELEMATICS
IGN	37	5	FUME DETECTOR
IGN	38	5	LECM / MIRR TEMP
IGN+	39	10	MACK DYNAMIC STEERING
IGN+	40	5	LCP/LCM
BATT	41	30	ABS
BATT	42	10	OPEN
BATT	43	15	LECM2
BATT	44	10	KEY SWITCH/M-DRIVE START
IGNSW	45	5	OPEN
IGN	46	15	OPEN
IGN	47	30	BB IGN-Y
IGN	48	15	HEATED WINDSHIELD
IGN	49	15	REVERSE LAMPS/LIFT AXLES
RLY 18:87	50	20	M-DRIVE TECU
RLY 18:87	51	10	M-DRIVE GECU
BATT	52	10	INSTRUMENT CLUSTER
EMS	53	5	BBM
EMS	54	10	TRANS/PARKER PTO
IGN+	55	10	OPEN
IGN+	56	10	BENDIX FUSION
IGN+	57	15	SNOW PLOW LAMPS LH
IGN+	58	15	SNOW PLOW LAMPS RH
IGN+	59	10	SEAT SRS
BATT	60	30	HVAC FAN
BATT	61	5	LVD SENS/ VENDOR TTU
IGN	62	10	CB POWER
IGN	63	15	CUST. /AUX. SW
IGN	64	15	OPEN
IGN	65	10	OPEN
BATT	66	30	M-DRIVE
BATT	67	10	TMP RP 1226
BATT	68	10	RADIO
EMS	69	10	VECU
EMS	70	10	PTO

BATT	71	15	CENTER PIN HOT
IGN+	72	5	OPEN
IGN+	73	5	ACC / SIDE SENSE / ECS
IGN+	74	10	OPEN
IGN+	75	25	WIPER
BATT	76	30	ISO 3731 PLUG
BATT	77	10	BENDIX FUSION
BATT	78	25	LCM2
BATT	79	25	LCM4
BATT	80	10	DIAGNOSTIC CONNECTOR
BATT	81	20	LCM1
BATT	82	20	LCM6
BATT	83	20	LCM5
BATT	84	10	POWER DOOR LOCKS
BATT	85	5	TGW
BATT	86	10	ECS
BATT	86	15	BEACON LAMPS
BATT	87	15	CUSTOMER BATTERY 1

FUSE PART NUMBER, COLOR ADD TYPE CHART (MINI FUSES)

FUSE RATING	PART NUMBER	COLOR
5A	20378932	TAN
10A	20378934	RED
15A	20378935	BLUE
20A	20378936	YELLOW
25A	20378937	NATURAL
30A	20378938	GREEN

RELAYS

RELAY POSITION	DESCRIPTION
R1	ACCESSORY POWER
R2	RADIO WAKE
R3	NEUTRAL POWER
R4	VENDER START ENABLE
R5	CENTER PIN HOT
R6	ISO PIN HOT
R7	SNOW PLOW RH
R8	SNOW PLOW LH
R9	OPEN
R10	CITY HORN
R11	START ENABLE

R12	HVAC BLOWER
R13	SNOW PLOW LCM INPUT
R14	LIFT AXLE / REVERSE SIGNAL
R15	ALLISON BODYBUILDER
R16	ALLISON BODYBUILDER
R17	POWER IGNITION 1
R18	M-DRIVE POWER
R19	EMS 2
R20	IGNITION +
R21	OPEN
R22	ECS POWER
R23	INTERMITTENT WIPER
R24	INTERMITTENT WIPER
R25	OPEN
R26	OPEN

Note: FRC decal part number is 23904441

Note: Fuse and relay information could be different. Refer to your Owner's manual.

External Fuse Relay Center (EFRC)

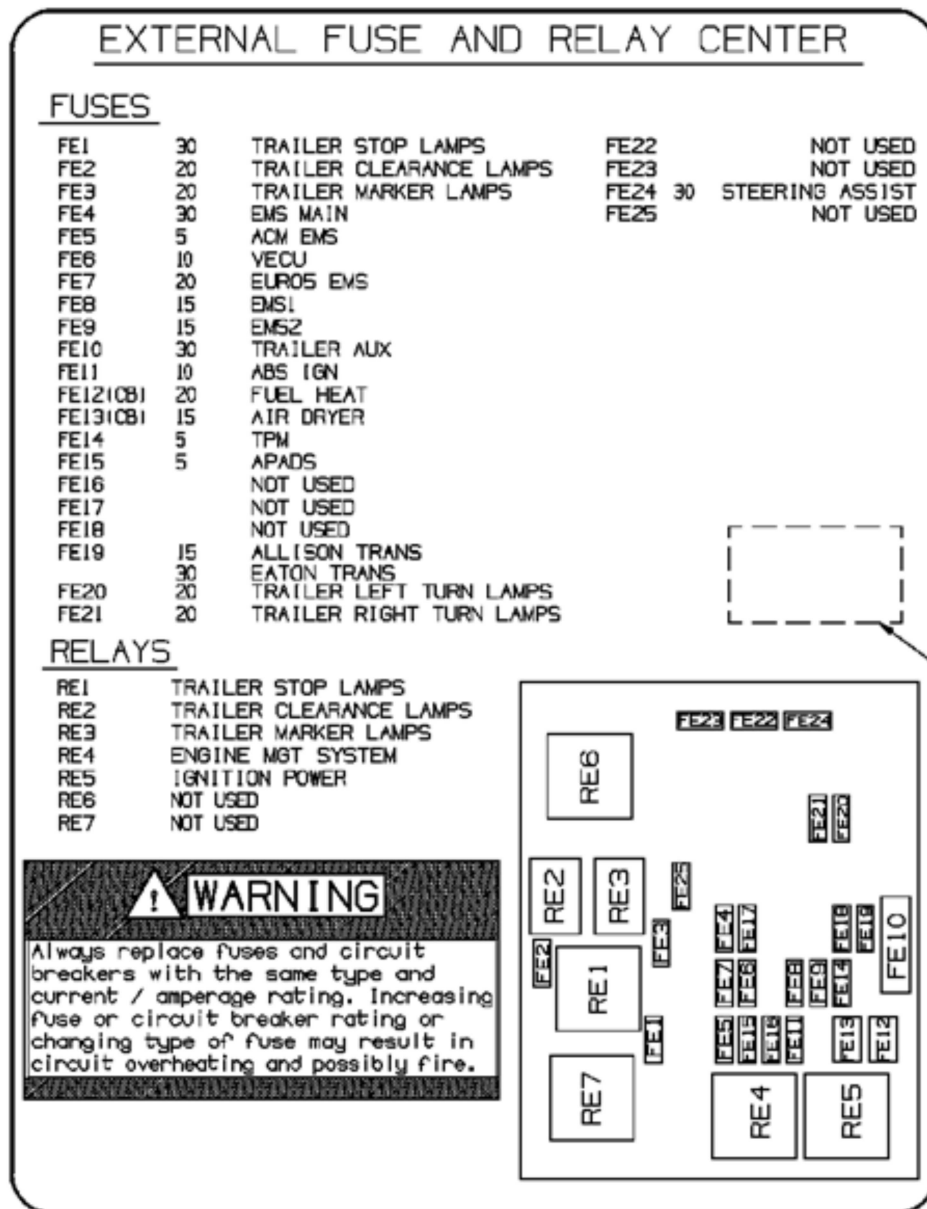

T3202111

Note: No decal available for EFRC. Comes with the cover.

Fuse Relay Center for TE

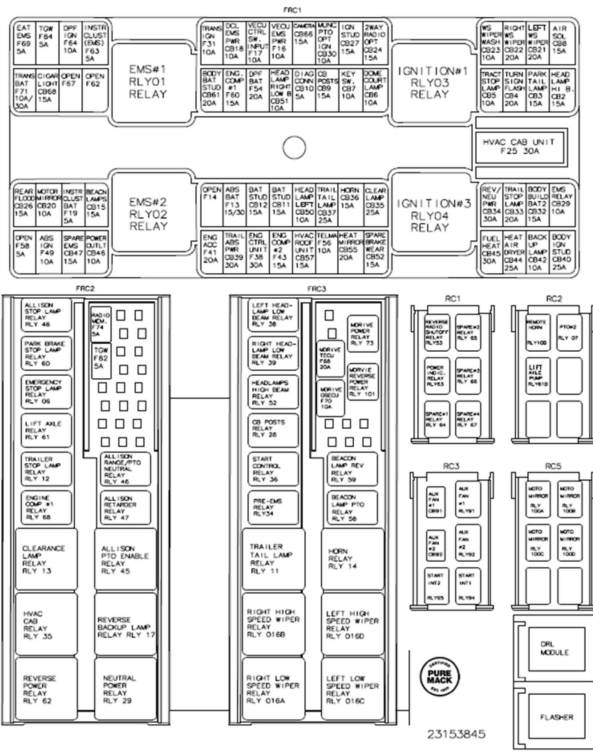

T3202112

Note: Fuse and relay information could be different. Refer to your owner's manual.

Fuse Relay Center for LR

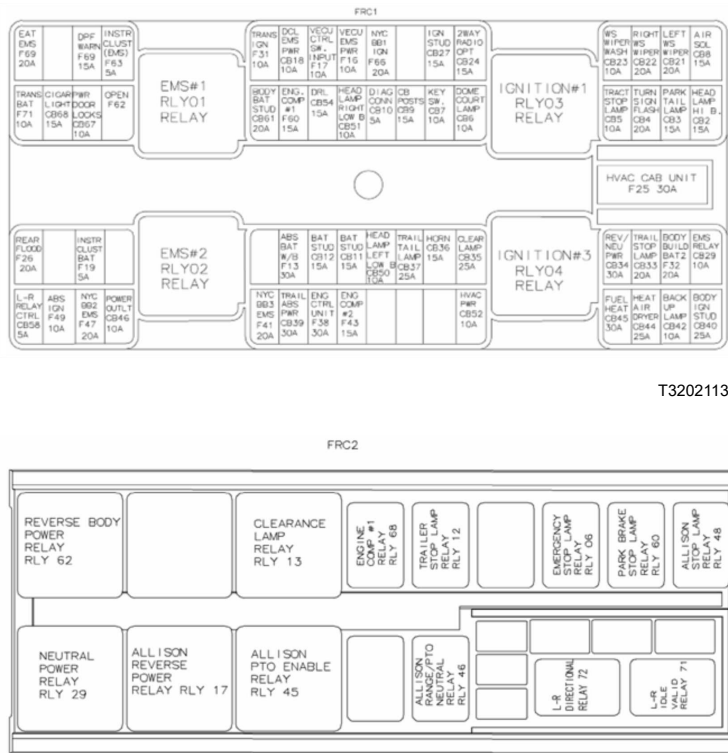

T3202113

T3202114

FRC3

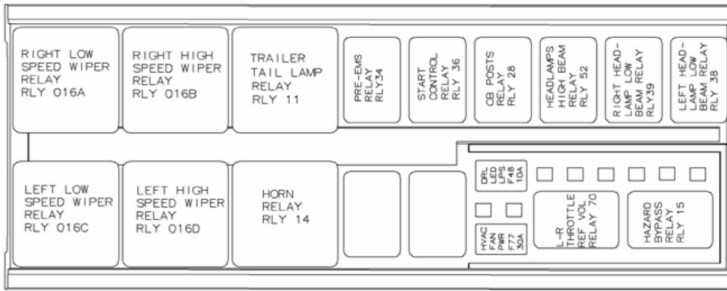

T3202115

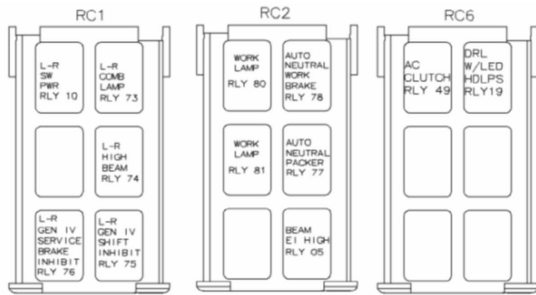

T3202116

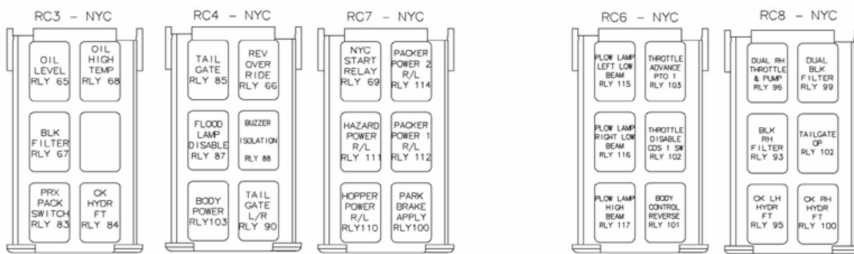

T3202117

Note: Fuse and relay information could be different. Refer to your owner's manual.

Routing and Clipping Guidelines

- 1 Brackets used in routing and clipping should be Material Grade 50 or better to ensure sufficient clamp load when sharing joint connections with cross members or other structural members. This applies only to joint connections using a low nut. Brackets of Material Grade 30 are acceptable provided the shared joint is using a high nut. The area of the clip bracket under the bolt head must be a least as large as the bolt head itself.
- 2 Clips that scratch exterior mounting surfaces shall not be used (i.e., barbed/spring type) unless the material is non-corroding (i.e., plastic). Clips must have rust protection.
- 3 Clip sizes should adequately secure the bundle without restricting flow, causing collapse, or preventing relative movement.
- 4 Bundles shall be supported at 24 inches (600 mm) maximum intervals, a cable tie should be used between clip points on bundles with the exception of electrical wiring harness, which shall have a maximum support distance of 18 inches (450 mm) and a cable tie on bundles between clip points. When air and electrical lines are bundled together, the commodity with the greater cross-sectional area may determine the support spacing. A minimum of two cable ties shall be used between clip points to bundle electrical lines when the larger interval is used.

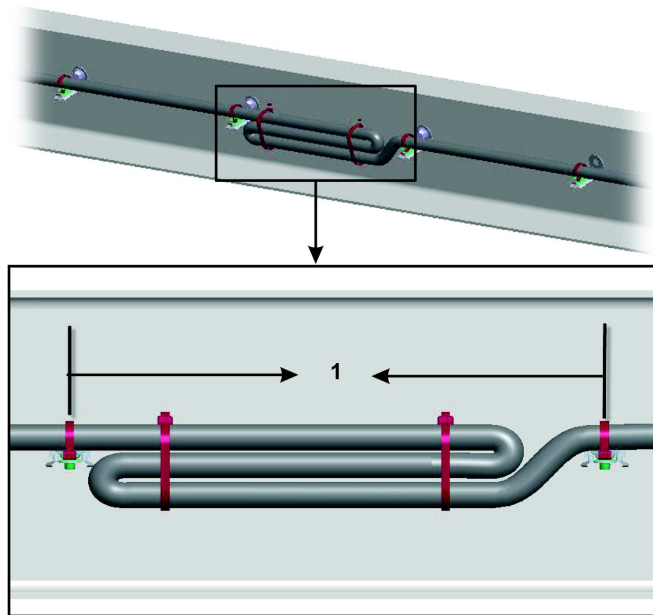

W3104131

1 Support electrical cables every 18 inches (450 mm)

Support Distances, Continued

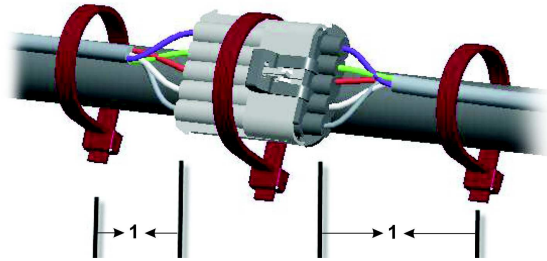

W3104144

1 Support cables near connectors every 4 inches (100 mm)

- 1 Electrical cables and wiring harnesses are to be secured 4 inches (100 mm) from the wire insertion end of the connector or clipped to the body.
- 2 Routing and clipping on purchased components (i.e., engine/transmission) should not include removing or replacing a bolt(s), nut(s) or screw(s) installed by the manufacturer. In such cases where this is unavoidable, the bolt(s), nut(s) or screw(s) shall be reinstalled to the manufacturer's specifications.
- 3 Bundles should not contact sharp edges of cross members. Contact may occur if it is against a smooth surface, a smooth radiused edge or a coined edge and the bundle is secured to prevent independent movement.
- 4 Hoses, tubing, pipes and electrical conduits shall not rub each other but may touch.
- 5 The fabric braided portion of the compressor discharge hose is compatible to be bundled with all routed air lines.
- 6 The compressor discharge pipe shall be routed independent of all other routing.
- 7 Electric cables/harnesses must not be bundled with fuel or hydraulic lines. The electrical cables/harnesses may be routed parallel with fuel or hydraulic lines, however must remain separated by approved clipping materials. When design control is possible, electrical cables/harnesses will be routed above fuel or hydraulic lines. If fuel or hydraulic lines must route above circuit protected electrical cables /harnesses, the fuel or hydraulic lines will have no fittings or potential leak points above electrical cables/harnesses and shall be minimized to the shortest distance possible over low current electrical cables/harnesses.
- 8 All associated markings on air and electrical harnesses should have a corresponding clipping apparatus.
- 9 Critical clipping locations shall be designated on the component to insure proper placement in the vehicle (i.e., tape).
- 10 Maximum support distance for compressor discharge rigid pipe, 30 inches (762 mm). Pipe to be isolated from support brackets (i.e. rubber isolator).
- 11 Maximum support distance for compressor discharge flex hose, 24 inches (600 mm).
- 12 Compressor discharge line should have a constant fall from compressor to air dryer. A dual fall is allowable provided it occurs on the engine and within 24 inches (600 mm) of the compressor.
- 13 Maximum allowable dip in compressor discharge pipe/hose is one half the outer diameter of the pipe/hose. Preferred routing should have no dips in any of the routings. This is to avoid line blockage due to water collecting and freezing in the line.

Heating Specifications

In order to maintain the integrity of the cables and hoses, observe the following specifications for routing near a heat source.

Cable, hose, or harness type	Specification
Electrical cables and wiring harnesses	5 inches (130 mm) in all directions from turbocharger, exhaust components and other high heat components
Unprotected hoses, tubing, harnesses, and cables	6 inches (150 mm) above, 5 inches (130 mm) beside and 4 inches (100 mm) below
Hoses, tubing, harnesses and cables protected by reflective heat sheathing	3 inches (76 mm) above, 2 ½ inches (63.5 mm) beside and 2 inches (51 mm) below
Silicone transmission coolant hoses	2 inches (51 mm) from exhaust manifold and turbo (with reflective heat sleeving), 1 inch (25 mm) from exhaust pipe
Hoses, tubing, harnesses, and cables protected by a heat shield (no reflective sheathing)	3/8 inch (10 mm) between the component and the heat shield. (Not valid for fuel lines)
Refrigerant suction hoses	8 inches (200 mm)

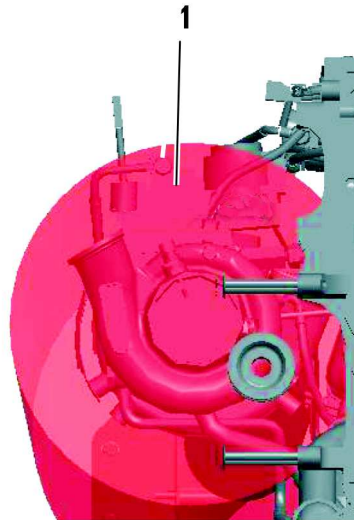

W3109897

1 Heat Radius from the Turbocharger, Front: 5 inches (130 mm)

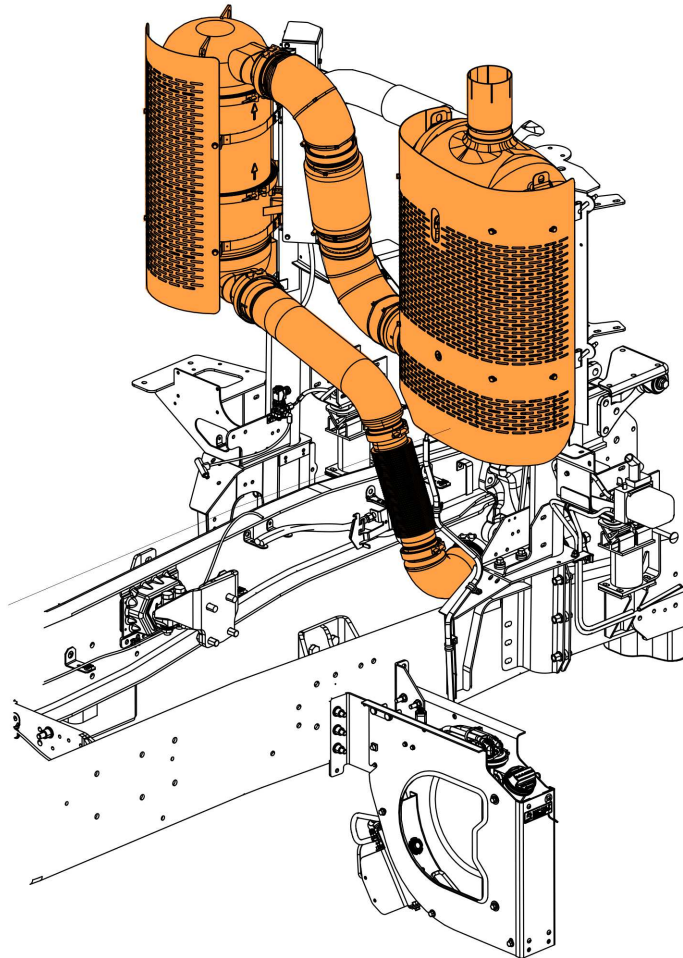

W2106268

The SCR, DPF and exhaust piping generate substantial heat. Keep electrical cables away from these components.

Clipping Guidelines

Clipping brackets should be designed and mounted to adequately support the bundle. Clips should be mounted in a hanging position or supported along three-quarters of the horizontal mounting surface. Orientations that do not conform to the illustrations shall be tested.

- 1 When hoses, wires and cables cross one another, secure them with a clamp. This prevents the sawing motion that could abrade them.
- 2 When routing flex hoses that are bent in two planes, clip them to prevent twisting. Clamp the hose at the point where the hose changes planes. The clamp has the effect of dividing the hose into two assemblies. If the section of the hose is bent in the same plane as the movement, the bend will absorb the movement and the hose will not twist.

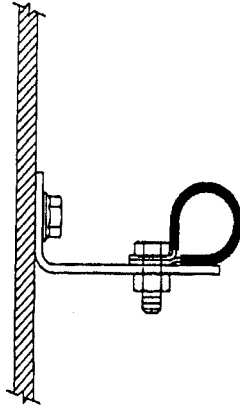

ACCEPTABLE

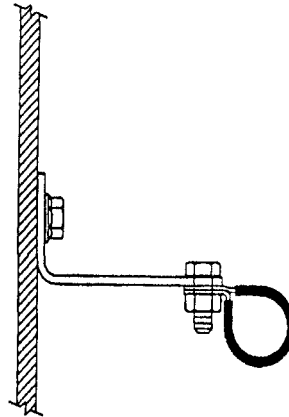

NOT ACCEPTABLE

W3103550

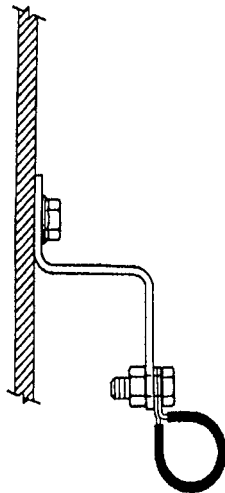

ACCEPTABLE

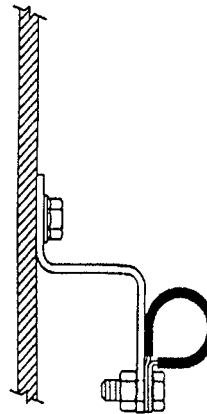

NOT ACCEPTABLE

W3103553

When routing connectors with cable ties, ensure that the cable ties do not contact the connector locking tab. Cable ties should also not contact the bare wire.

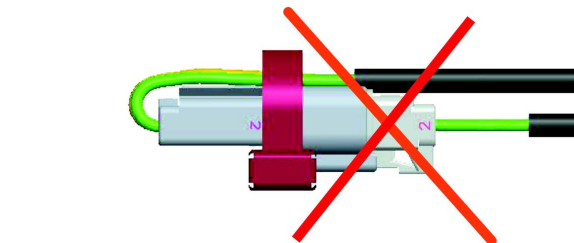
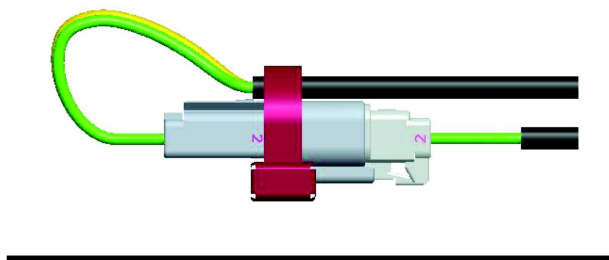

W3104148

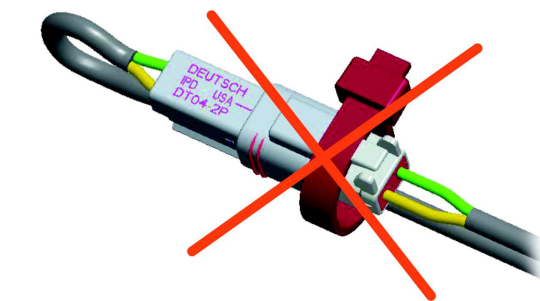
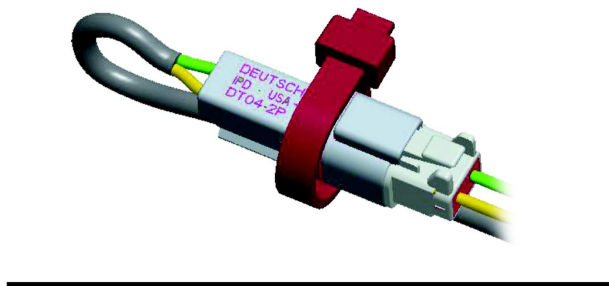

W3104149

Battery Cable Guidelines

The battery cable guidelines prevent electrical interference that can occur from improperly routed cables. In addition, the guidelines prevent cable damage through abrasion.

- 1 Battery cables with standard SAE stranding shall be supported at 16 inches (400 mm) maximum intervals. A separator type cable tie or an independent separator with cable tie may be used between clip points. No relative movement may occur between cables. If two (2) cable separators are used, they are to be installed equidistant from each other and arranged on a straight line, a maximum span between clip points of 24 inches (600 mm) may be used.
- 2 Strain relief clipping shall be provided for the battery and starter motor terminals. The strain relief clip shall be located with no relative motion to the terminals. The strain relief clip should be located close to these terminals and shall be within 20 inches (500 mm) cable length to the starter terminals.
- 3 Grommets shall be installed at points where cables pass through sheet metal or frames.
- 4 Routing shall avoid exposed edges of frame members, abrasive surfaces and all sharp edges. When routing inside the frame, ensure that no contact with the frame is made with uncovered cables. Uncovered battery cables, external of the battery box, shall be routed independent of all other conduits. Covered cables may be bundled with other similarly covered conduits and air piping with a secured separator. **Do not route with/under fuel lines.**
- 5 Cables should be clipped as close as possible to all cable bends.
- 6 Battery cables shall not be located within 5 inches (130 mm) of engine exhaust related components or other heat sources without heat coverings or heat shielding. Testing shall be performed to determine effects of closer allowances and the use of heat shields. Battery cables should not be installed in any area directly above engine exhaust related components.
- 7 Where cables flex between moving parts, the last supporting clip shall be securely mounted such that relative movement does not promote chaffing.
- 8 Battery cables shall not support any mechanical loads other than their own mass.
- 9 Minimum bend radii of battery cables should be 3 times the cable diameter for standard SAE strand cable.

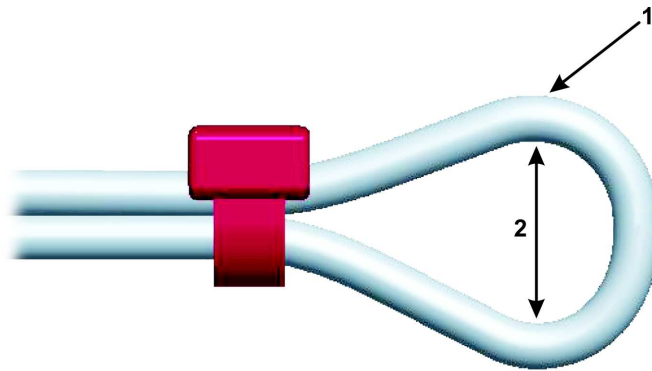

W3104133

1 Tube Diameter

2 Circle Diameter (3 x Tube Diameter)

Battery Guidelines, Continued

- 1 Star washers shall not be used on current path connections including grounds.
- 2 Asphalt type loom shall not be used for battery cable protection applications.
- 3 Battery cables shall not rub each other or surrounding items, but may touch when all items have no independent movement. Uncovered battery cables may not touch each other outside the battery box.
- 4 All exposed exterior to cab circuit ends shall be coated with a dielectric protective coating. Thickness to be 0.13 – 0.3 inches (3.5 – 7 mm) wet, full coverage, 3 inches (76.2 mm) diameter, or shall be completely covered with required inhibitor.
- 5 Clip orientations should be per illustration or installation drawings utilizing compression or heavy-duty clip.
- 6 Plastic conduit may be bundled and cable tied with covered battery cables when all items have no independent movement with each other. Battery cables may touch each other, plastic conduit or the battery, inside the battery box.
- 7 Covered battery cables may be securely tied or clamped to each other if no independent movement exists. Cables attached to the same terminal stud may be tied or clamped to each other.
- 8 Battery cable ends at the starter motor posts should be installed and positioned first with the engine harness terminals assembled after. Starter terminals that come with the starter may be first on the starter studs. Terminals shall not be reconfigured or bent.
- 9 Frame bolt placement, adjacent to the battery box, should have the bolt or screw threaded end facing away from the battery box and any related cables. Wrench grip type bolts should not be used in the frame at the battery box area. Non-wrench grip type bolt or screw threaded ends may face toward the battery box only if clip bracketing or shielding shall be provided to prevent any possible cable contact with frame-mounted hardware. Bolts that mount the battery box to the frame may be oriented toward the battery box.
- 10 Added abrasion protection should be used where the cable contacts other routed commodities or surfaces with no independent movement such as frame rail surfaces or transmission and engine castings. Polyethylene, polypropylene, nylon conduit and thick wall heat shrink tubing may be used for added abrasion protection.
- 11 Cables should be located to afford protection from road splash, stones, abrasion, grease, oil and fuel. Cables exposed to such conditions should be further protected by either, or a combination of, the use of heavy wall thermoplastic insulated cable, additional tape application, plastic sleeve or conduit.
- 12 Anytime an existing fastener is used to secure a clipping bracket (or any similar device), the fastener shall be retorqued to the value specified in the original documentation given for the fastener.
- 13 Each exposed exterior circuit end must be coated with a dielectric protective coating. Thickness to be 0.13 – 0.3 inches (3.5 – 7 mm) wet, full coverage, 3 inches (76.2 mm) diameter.
- 14 Do not use box clamps to secure battery cables.
- 15 In addition to berringer clamps, use double-head tie clamps.

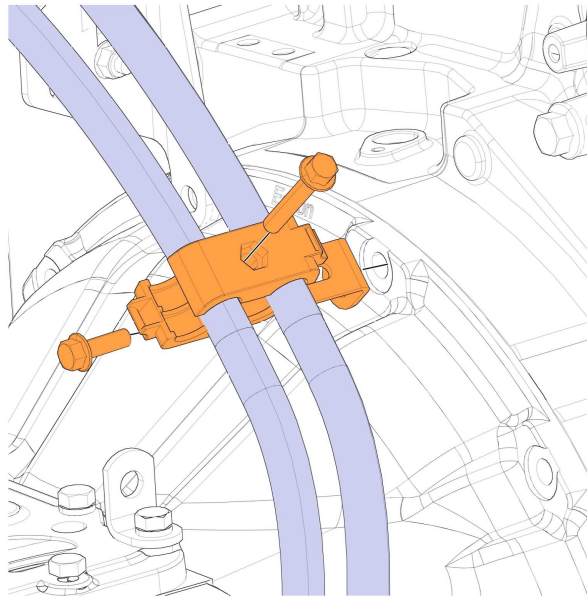

W3077595

Berringer clamps are recommended for securing battery cables to each other.

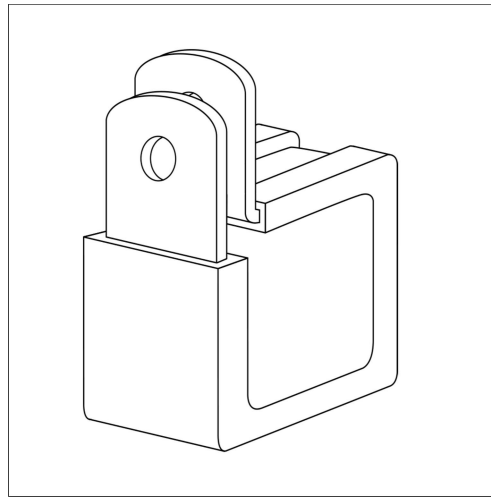

W3105372

Box Clamps (shown above) are NOT to be used for securing battery cables to each other.

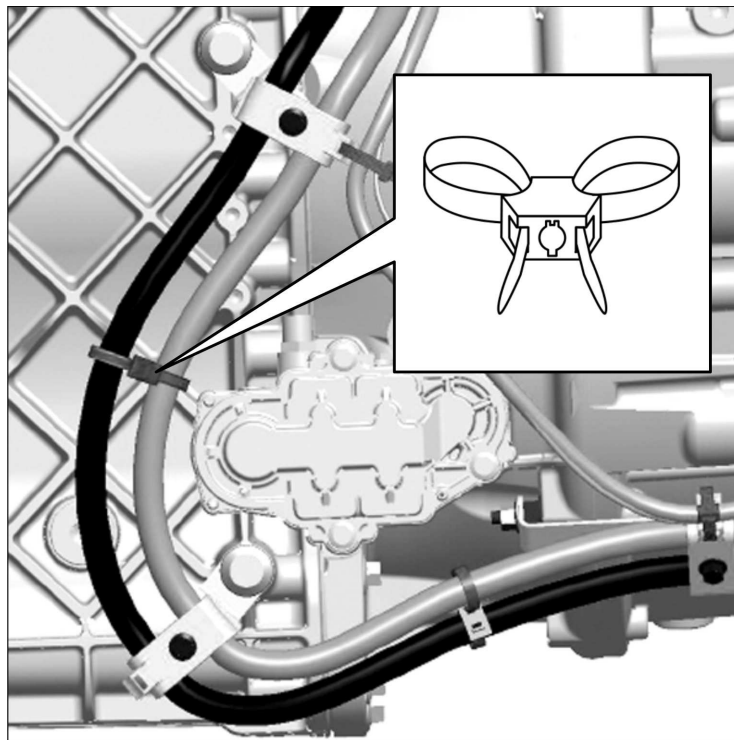

W3105374

Double-head tie clamps may be used to route battery cables.

Ring Terminal Assembly

Assemble terminal carrying the highest current (largest gauge wire) first, then graduate to the smallest gauge up to the fastener. Use a maximum of three (3) terminals per stud (unless otherwise specified on an illustration drawing).

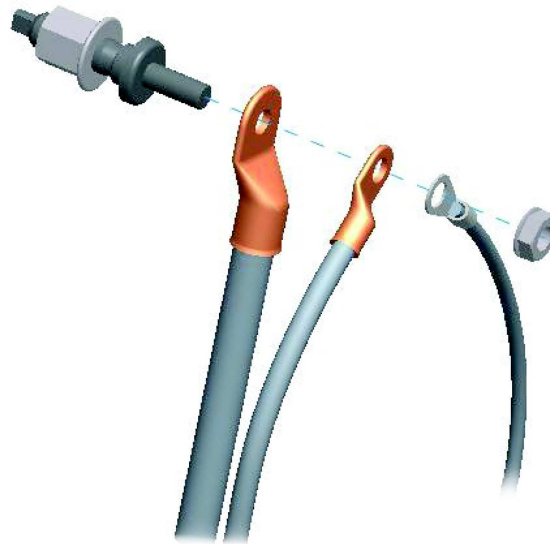

W3104152

When attaching ring terminals with a fastener, tighten the fastener to appropriate torque so that the contact area will touch the terminal at any point, in a full circle that is part of the terminal.

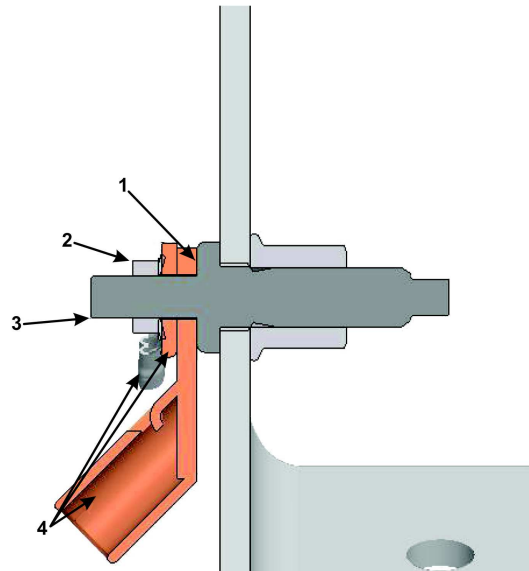

W3104153

- 1 Contact Area
- 2 Fastener
- 3 Stud
- 4 Terminals

When attaching multiple terminals, position the terminals at an angle to allow maximum contact of the terminal surface. Terminals are not allowed to bend other than their natural form. Terminals may be stacked back to back.

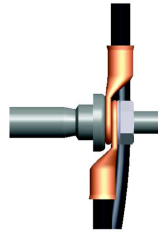
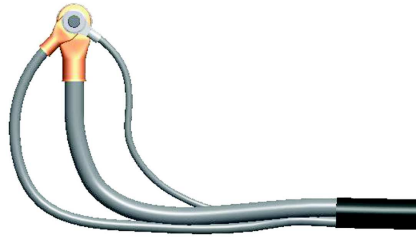

W3104154

Improperly fanned terminals result in unacceptable bends.

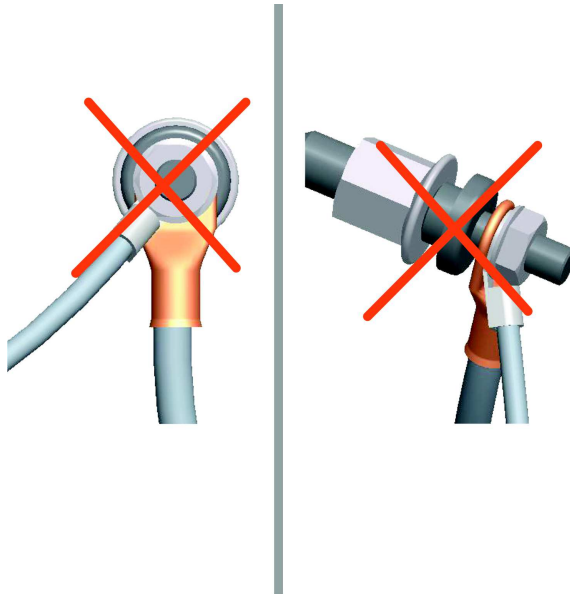

W3104155

NOx Sensor Routing

The NOx sensor requires unique routing considerations. The NOx sensor harness must not be bundled with other wiring harnesses. However, it may be routed with other harnesses as long as they are not high voltage cables. The sensor harness is a set length and no altering or modifying of the NOx sensor harness is allowed.

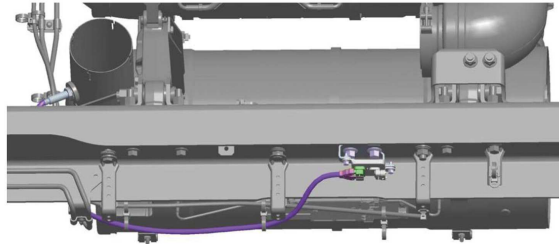

W3104156

Conventional

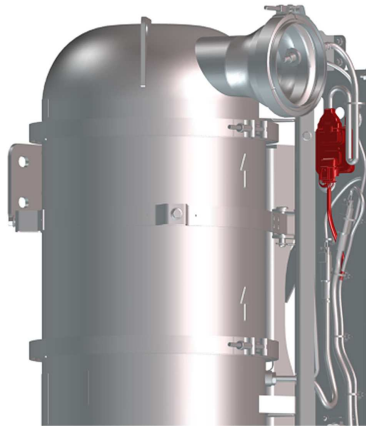

W3109892

Cab over

Note: DO NOT splice into a V-MAC, ABS/ATC or any other electronic control unit harness.

Do not cut or tap into the J1939 green/yellow twisted wires or any other wire or harness used on this vehicle. Use the provided connectors, and only add approved J1939 components with validated software. Failure to comply may result in personal injury or equipment damage. Any cutting, splicing, alteration or modification to the wiring will Void the Mack Trucks Warranty on the Electrical System.

Body Builder Connectors, Schematic Examples

Third-party devices are often installed on Mack Trucks. These devices need information (vehicle speed, gear, etc.) to operate safely and efficiently. However these devices are not quality controlled as far as MACK is concerned, and are not part of the main control databus. Therefore, MACK provides an external connector to supply a body device with the necessary information it needs to function properly.

Mack Trucks do not use an external body builder module (BBM). In Mack Trucks, the functions of the BBM are managed by the Vehicle Electrical Control Unit (VECU) and are transmitted to the body device via an SAE J1939 connector. SAE J1939 is a communications link between standalone vehicle modules. This data link is commonly referred to as the "Control data link". It is used primarily to transmit control signals that are shared between other standalone modules. The information on the SAE J1939 control link is used for control functions. Fault messages or diagnostic information also transmits across this link. These control signals may be for engine, transmission, brakes or a number of other vehicle controls needs. The J1939 operates at 250,000 bits per second (250 Baud Rate), which is approximately 26 times faster than the J1708/1587 data link. This higher speed allows the system to operate at a faster sampling rate and higher resolution, thus enabling better control of vehicle functions.

Terminating Resistors

Terminating resistors are wired to each end of the SAE J1939 data link to prevent signal reflections. They must remain connected for the data link to function properly. The resistance value of each termination resistor is 110 – 130 Ω . When properly installed in the data link, their combined resistance is 50 – 70 Ω since they are connected in parallel.

The termination resistor at one end of the SAE J1939 data link is located in the fuse and relay centre (FRC) near the vehicle electronic control unit (VECU) and the other near the engine control module (ECM). On vehicles equipped with MACK engines, the termination resistor at the engine end is located inside the ECM. On vehicles equipped with Cummins engine, the termination resistor is located in the harness area just outside of the ECM.

A SAE J1939 data link connection is located at the transmission area in the chassis harness. On vehicles equipped with an electronically controlled transmission (Allison/Autoshift II/Meritor Freedom Line), the connection to the transmission is located at the chassis harness. On vehicles equipped with a manual non-electronically controlled transmission - the connector stub will have an unterminated blanking plug installed.

Only two termination resistors are used in each data link. Never install more than two terminator resistors in one data link. If more than two resistors exist in the SAE J1939 data link circuit, incorrect or absent signals may occur. You can easily check to see if you have two resistors by measuring the resistance between pin C and D for the 9-pin diagnostic connector, or pin 3 and 11 for the 16-pin diagnostic connector, with the ignition key in OFF position. The correct resistance is 50 – 70 Ω . The termination resistors should each have a resistance of 110 – 130 Ω when tested individually.

Notes

Electrical Wiring and Connections

Main Power and Starting Circuits

Figure 1 shows the starter circuits. Note that the EMS and VECU directly control the starter relay. The EMS inhibits starter for engine running, starter overheat and PTO. The VECU inhibits the starter mainly for transmission in gear.

Figure 2 shows the main power circuits. Ignition and “EMS” power are controlled by the VECU through relays. “EMS” power is connected after the key is turned on and remains on during crank and for some seconds after key off, mainly to service the Engine Management System. Ignition power is similar, but is disconnected during crank and supplies items not necessary for engine start. MACK conventional trucks actually have a second set of ignition circuits for items not normally needed for driving (e.g. Sleeper) which also supplies one of the Granite BodyLink III power pins indicated in Figure 14. The first and second power relays are also shut off at low voltage. The first relay powers off at a lower threshold than the second.

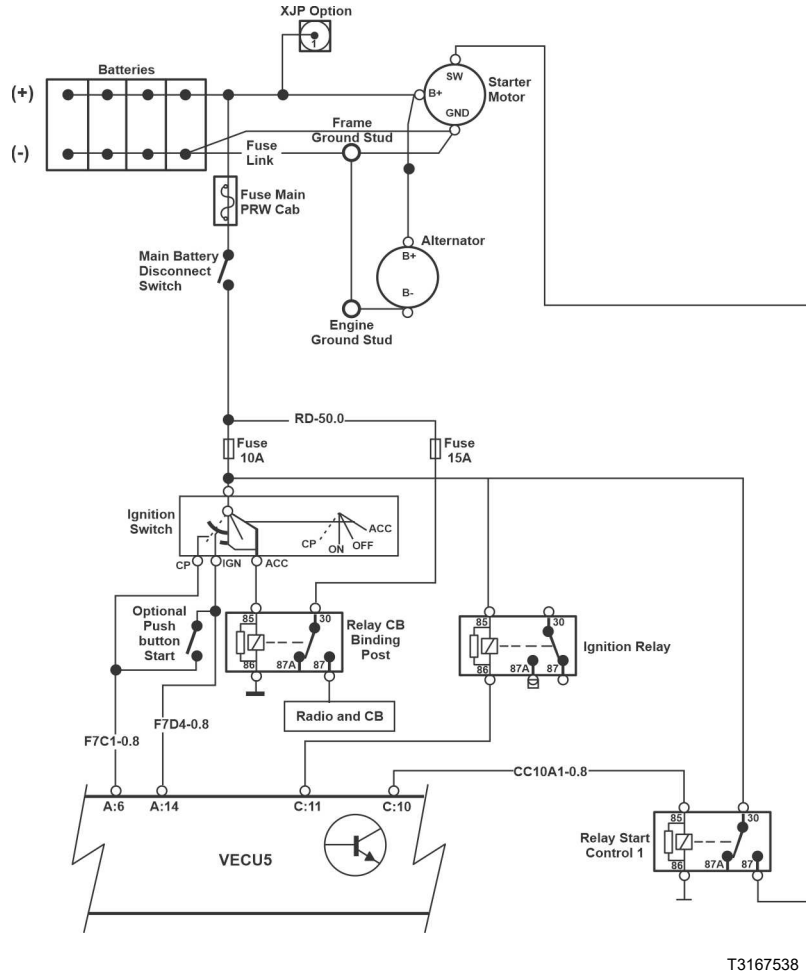
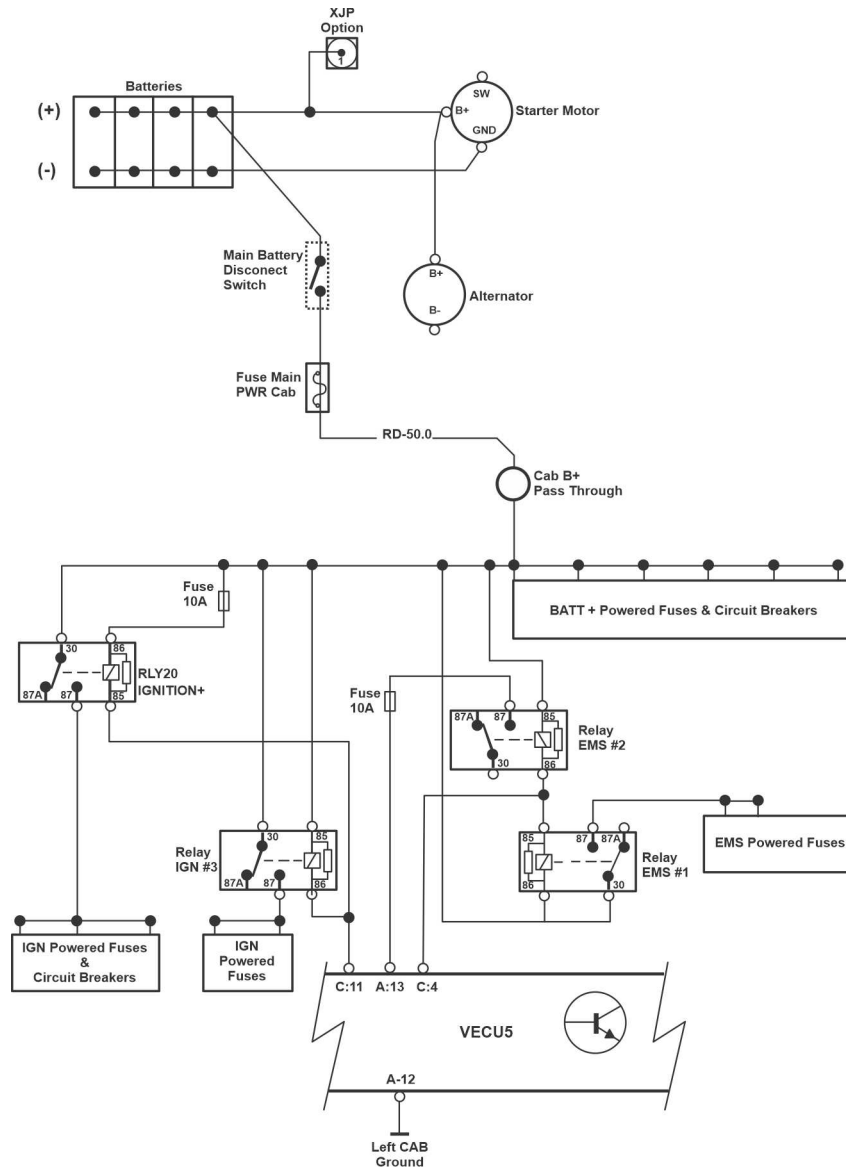

Fig. 1 TE, LR Main Power and Starting Circuit



T3167552

Fig. 2 Battery & Ignition - Switched Supplies - Conventional Trucks

“IGN” circuits will be disconnected at LOW VOLTAGE and during STARTING.

“EMS” circuits remain powered while at key ON or CRANK and may remain powered at key OFF.

Buffered Ground Speed Signal X156 / BB-OPT connector

The body builder can use option connector (X156 / BB-OPT) to access the buffered vehicle speed & rpm signal.

Part number for body builder option mating connector (X156 / BB OPT) is – 8077130,
terminal x 2 – 25161233
lock – 8397688.

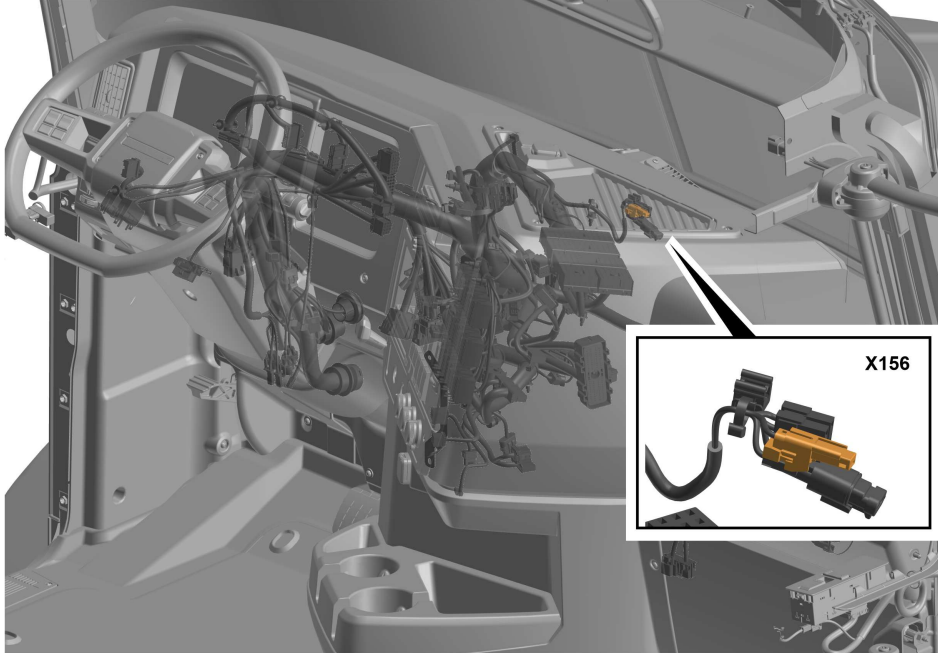

T3192424

Note: GR (Granite) built week 37 of 2023 and later will have the X156

Note: Parameter P13NU should be set to 2 for road speed.

Note: AN and PI Models will not have this connector. If ground speed signal is required, it can be obtained from the Instrument cluster connector A cavity 2

Vehicle Control Unit (VECU) Connections

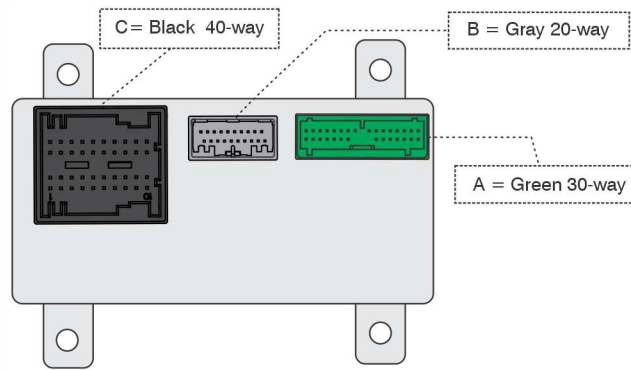

T3167529

Fig. 3 Vehicle Control Unit (VECU) Connectors, Mack Conventional

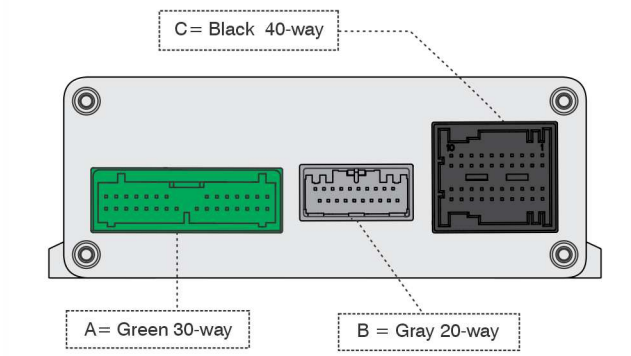

T3167530

Fig. 4 Vehicle Control Unit (VECU) Connectors, Mack Cabover

Description of VECU Pin Layout

VECU Connector A (Green)

Pin Number	Type	Function Description		
		Conventional	Cabover	
			LR	TE
CN1:1	DIH1	Cruise Control: Set- / De-acceleration	Cruise Control: Set- / De-acceleration	
CN1:2	DIH2	Cruise Control: Set+ / acceleration	Cruise Control: Set+ / acceleration	
CN1:3	DIH3	Cruise Control: On/Off	Cruise Control: On/Off	
CN1:4	DIH4	Fan Override	Spare	
CN1:5	DIH5	Brake Pedal	Brake Pedal	
CN1:6	DIH6	Crank Position	Crank Position	
CN1:7	DIH7	Spare	PTO3	
CN1:8	DIH8	Clutch	Spare	Clutch
CN1:9	DIH9	Spare	Air Suspension	
CN1:10	DIH10	AC ON/OFF	AC ON/OFF	
CN1:11	DOL8	Fifth wheel Slide	Spare	
CN1:12	ECU GND	ECU Ground	ECU Ground	
CN1:13	ECU BATT	ECM Power	ECM Power	
CN1:14	DIH11	Key Switch Ignition	Key Switch Ignition	
CN1:15	CAN-2-H	J1939/ISO-2-H (BB2)	J1939/ISO-2-H (BB2)	
CN1:16	CAN-2-L	J1939/ISO-2-L (BB2)	J1939/ISO-2-L (BB2)	
CN1:17	DIH12	ACC Time Gap +	Spare	
CN1:18	DIH13	PTO 2 Request	PTO 2 Request	
CN1:19	DIH14	PTO 1 Request	PTO 1 Request	
CN1:20	DIH15	Ebrake Set + Cummins	Ebrake Set Sel2	
CN1:21	DIH16	Ebrake Set - Cummins	Ebrake Set Sel1	
CN1:22	EOL	EOL	EOL	
CN1:23	DIH18	IVS1	IVS1	
CN1:24	DIL1	Spare	WIF Switch	
CN1:25	DIL2	Interwheel Lock (front)	Spare	
CN1:26	DIL3	InterWheel Differential Lock (Front or (Front and rear))	InterWheel Differential Lock (Front or (Front and rear))	
CN1:27	DIL4	Spare	RH Operation	Spare
CN1:28	DIL5	Interaxle Differential Lock	Interaxle Differential Lock	
CN1:29	DIH19	Spare	PTO4	
CN1:30	DIH20	Fifth wheel Slide Switch	Spare	DRL Override Switch

VECU Connector B (Gray)

Pin Number	Type	Function Description		
		Conventional	Cabover	
			LR	TE
CN2:1	NO Connection	NO Connection	NO Connection	NO Connection
CN2:2	NO Connection	NO Connection	NO Connection	NO Connection
CN2:3	DIH24	ACC Time Gap -	Spare	Spare
CN2:4	DIH25	Shut Down Override	Spare	Spare
CN2:5	DIH26	Spare	DRL Override Switch	Shut Down Override
CN2:6	DOL11	Spare	Spare	Spare
CN2:7	DOL12	Spare	DRL Control	DRL Control
CN2:8	AI6	Spare	Spare	Spare
CN2:9	AO3	Spare	Spare	Spare
CN2:10	AO4	Spare	Spare	Spare
CN2:11	NO Connection	NO Connection	NO Connection	NO Connection
CN2:12	NO Connection	NO Connection	NO Connection	NO Connection
CN2:13	AO6	Spare	Spare	Spare
CN2:14	CAN-4-H	Spare	Spare	Spare
CN2:15	CAN-4-L	Spare	Spare	Spare
CN2:16	CAN-5-H	Spare	Spare	Spare
CN2:17	CAN-5-L	Spare	Spare	Spare
CN2:18	A_GND 2	PB Sensor GND	PB Sensor GND	PB Sensor GND
CN2:19	A_GND 4	Spare	Spare	Spare
CN2:20	LIN	Spare	Spare	Spare

VECU Connector C (Black)

Pin Number	Signal Type	Function Description		
		Conventional	Cabover	
			LR	TE
CN3:1	DOL2	PTO 2 Output	Spare	
CN3:2	DOL3	Interwheel Differential Lock (Front or (Front and rear))	Interwheel Differential Lock (Front or (Front and rear))	
CN3:3	DOL4	Interwheel Differential Lock (Front)	Spare	
CN3:4	DOL5	ECM Relay	ECM Relay	
CN3:5	DOL6	Spare	Spare	Reverse Output
CN3:6	DOL7	PTO 1 Output	Spare	PTO 1 Output
CN3:7	DOL9	Cummins IVS	Cummins IVS	
CN3:8	DOL10	Spare	AUX Fan	
CN3:9	DOH1	IVS buffered output	IVS buffered output	
CN3:10	DOH2	Starter Control	Starter Control	
CN3:11	DOL1	Power Relay #1	Power Relay #1	
CN3:12	DIL6	Spare	Spare	
CN3:13	DIH17	PTO 1 OBD	Spare	PTO 1 OBD
CN3:14	DIH21	PTO 2 OBD	Spare	PTO 2 OBD
CN3:15	DIH22	Spare	Spare	
CN3:16	DIH23	Spare	Spare	
CN3:17	DIL7	Parking Brake	Parking Brake	
CN3:18	DIL8	Spare	Engine Shutdown	
CN3:19	DIL9	Spare	Spare	
CN3:20	DOH3	Interaxle Differential Lock Output	Interaxle Differential Lock Output	
CN3:21	AI1	Accelerator Pedal Signal	Accelerator Pedal Signal	
CN3:22	AI2	Spare	Spare	
CN3:23	AI3	Parking Brake OBD	Parking Brake OBD	
CN3:24	AI4	Spare	Spare	
CN3:25	AI5	Service Brake	Spare	Service Brake
CN3:26	AO1	Output Supply 1 (5 V)- Accelerator Pedal	Output Supply 1 (5 V)- Accelerator Pedal	
CN3:27	AO2	PB Sensor Power	PB Sensor Power	
CN3:28	AO7	Spare	Spare	
CN3:29	AO8	CC switch supply 12V	Spare	
CN3:30	AO5	Analog Supply- VSS and IVS Switch	Analog Supply- VSS and IVS Switch	

Pin Number	Signal Type	Function Description		
		Conventional	Cabover	
			LR	TE
CN3:31	CAN-1-H	J1939-1-H (BB1)	J1939-1-H (BB1)	
CN3:32	CAN-1-L	J1939-1-L (BB1)	J1939-1-L (BB1)	
CN3:33	CAN-3-H	DL5H	DL5H	
CN3:34	CAN-3-L	DL5L	DL5L	
CN3:35	A_GND 1	Analog GROUND - Accelerator pedal	Analog GROUND - Accelerator pedal	
CN3:36	A_GND 3	Spare	Spare	
CN3:37	J1587-A	J1587-A	J1587-A	
CN3:38	J1587-B	J1587-B	J1587-B	
CN3:39	FI	Speed sensor signal	Spare	Speed sensor signal
CN3:40	FI_GND	Speed sensor signal GROUND	Spare	Speed sensor signal GROUND

Notes

Remote Start n Stop

Note: This is only a suggestion for a body builder installed system.

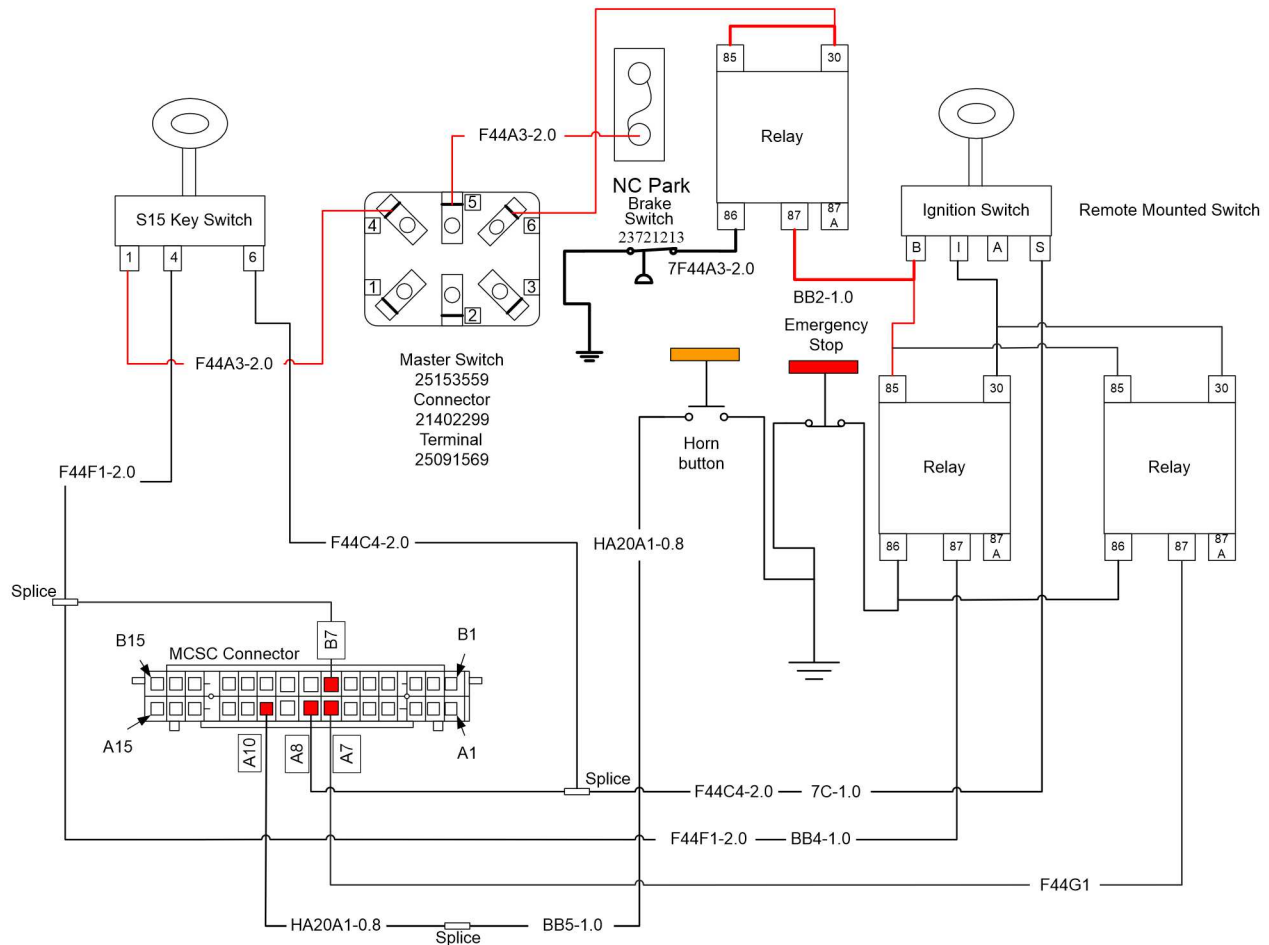

T3205215

Fig. 5 Remote Start N Stop VECU5

Note: Refer to “Remote Start N Stop VECU5, Schematic Components” table for descriptions and part numbers.

Make all splices at the Main cab harness behind the MCSC (Main Cab Steering Column) Connector.

- 1 All splices must be soldered and heat shrink tubing must be applied over splice.
- 2 Route harness thru Body Builder connector using spare pass through wires. BB2-1.0 = BB_CAB:14 BB3-1.0 = BB_CAB:15 BB4-1.0 = BB_CAB:16 BB5-1.0 = BB_CAB:17

Main Cab Wires to Body Builder Wires

- F44A3-2.0 to BB2-1.0
- F44C4-2.0 to BB3-1.0
- F44F1-2.0 to BB4-1.0
- HA20A1-0.8 to BB5-1.0

To Minimize wiring in cab, Body Controls can be wired into the Body Builder Connectors behind the cab.

Remote Start N Stop, Schematic Components

Description	Part Number
Relay	25171095
Relay Connector	20865681
Terminal	20865693 1.0 – 2.0
Terminal	20865699 0.5 — 0.8
Secondary Lock	25154889
Switch Drive Position	25153559
Switch Drive Position Connector	21402299
Terminal Drive Position Switch	25091569
Park Brake Switch	25171211

Notes

Remote Engine Stop

If a chassis was ordered with “Remote Engine Stop”, a relay is pre-installed in the harness. Installation of the push-button switch is all that is required.

If installing “Remote Engine Stop” to a chassis (TE, LR and Conventional Chassis’), relay P/N 25082390 must be installed in addition to installing the push-button switch. Only TE and LR models are pre-wired for the Remote Engine Stop.

Note: For Remote Engine Stop to work you must run an accessory kit and P/N 85137397 reprogram the VECU (Can only be done by a Dealer) and parameters need to be programmed. See “Remote Engine Stop” in the Body Builder, Parameter Programming service bulletin.

Note: The input to the VECU pin C:18 (Black 40-way connector on VECU) is an active low digital input that must be attached to an isolated signal ground.

DO NOT switch chassis/cab ground to pin C:18 of the VECU. Interference from other components on the chassis/cab ground could cause an engine shutdown when not requested by the body builder.

Note: The switching of ground to an input that carries a very low current requires special switching equipment. It is recommended using a switch with gold contacts, or a relay to switch the signal ground to Pin C:18 of the VECU.

Gold resists corrosion on the contacts and relays have enough ‘swiping’ motion on the contacts to help keep them clean.

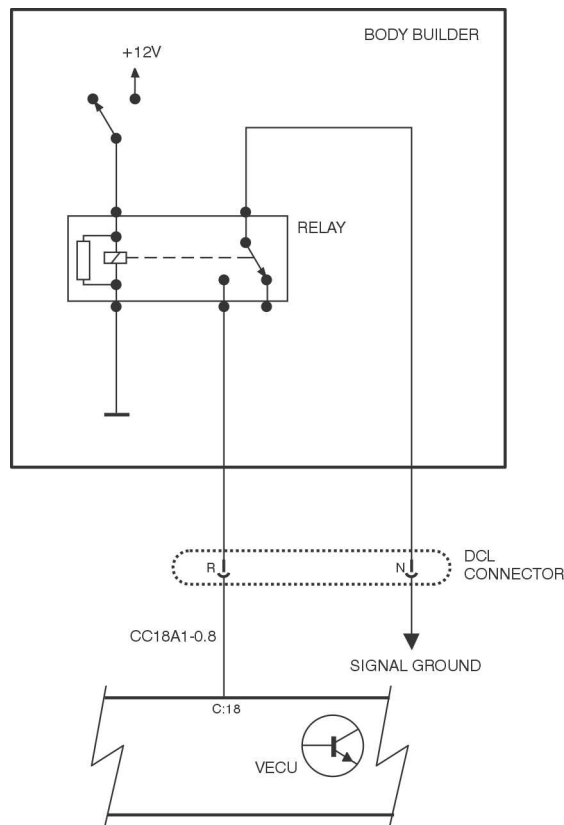

T2167534

Fig. 6 Remote Engine Stop, TE

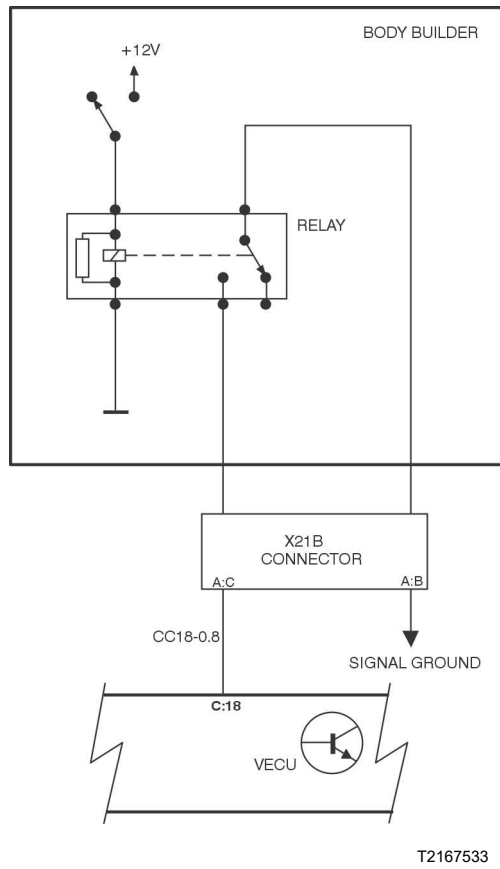

Fig. 7 Remote Engine Stop, LR

Notes

Adding Auxiliary Accelerator Pedal

Below is a suggestion for adding an auxiliary accelerator pedal, based on the Mack LR dual steering solution.

The pedal is wired in parallel using a multipin selector switch. If the signal is not switched between the two accelerator pedals, a fault code may be generated due to high current at the throttle pedal signal input line (VECU C:21).

Note: VECSee data link system before using such a device.

Note: An identical pedal is needed for the auxiliary sensor accelerator pedal because it requires an IVS signal. A substitute type pedal may cause a fault code and is not recommended.

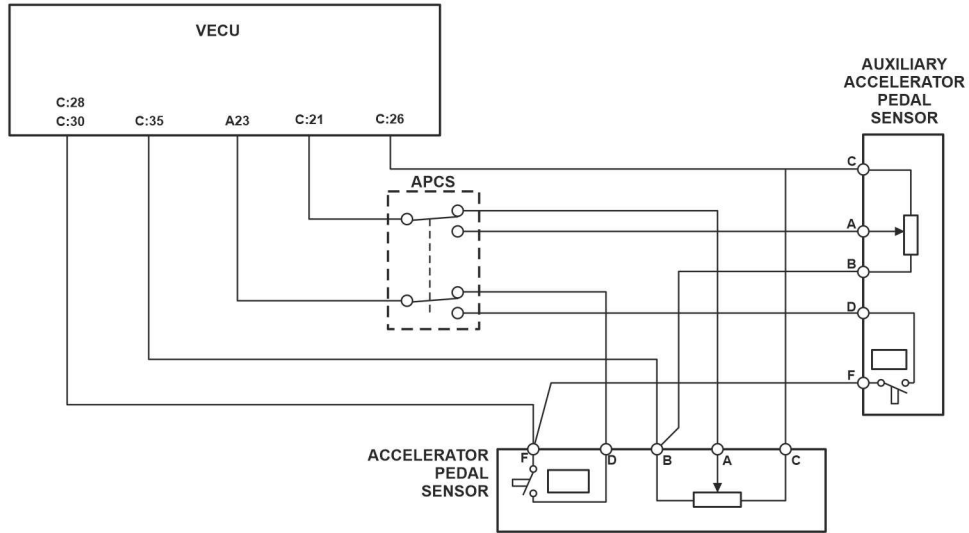

T3189429

Fig. 8 Auxiliary Acceleration Pedal Signal. Pin C28 is for convention and Pin 30 for LR and TE

Note: Refer to “Auxiliary Acceleration Pedal Signal, Schematic Components” table for component ID(s) and descriptions.

Notes

SIB Switch Instructions for Remote PTO Operation

Due to Emissions and On Board Diagnostic regulations, PTO switches now have an analogue and digital input to allow for diagnostics on the switch. Both PTO 1 and PTO 2 switches will come with this configuration.

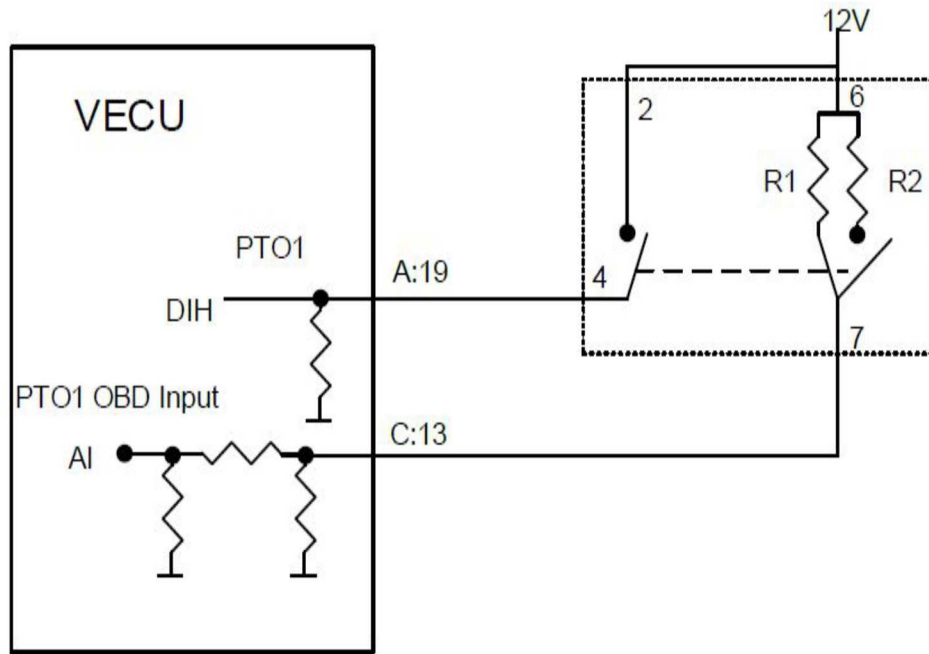

T3166523

The engine has diagnostic for misfire that is disabled while this switch is configured for diagnostic and is activated. If the truck is ordered without PTO switches, the PTO inputs can still activate engine speed control and PTO output as in previous models. However, this misfire diagnostic is no longer suppressed. Therefore, there is risk of engine misfire faults if PTO loads are significant without the resistive switch configuration. For these reasons, it is recommended that PTO functions use a factory installed PTO switch where possible.

Granite BodyLink III includes PTO 1 and 2 pins with both analogue and digital inputs so that a body located switch can also be installed (and can be placed in parallel with the dash switch). The digital pin can also be used as a switch output as in the past. Ideally, the dashboard switch with both analogue and digital pins would be used on the body where necessary.

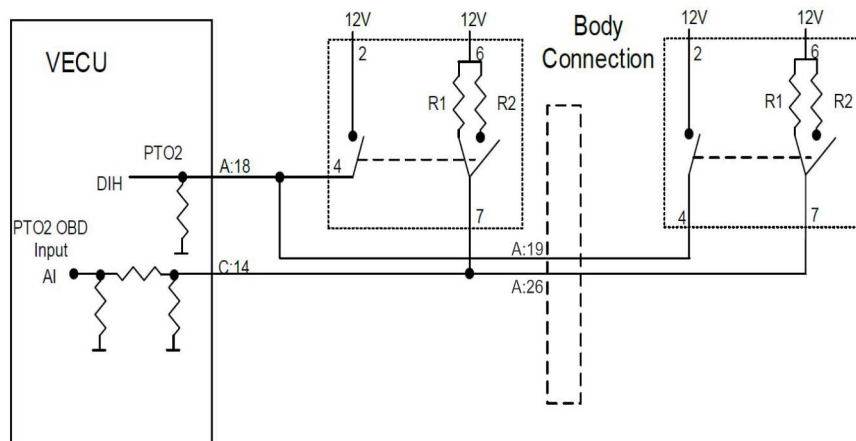

T3180150

Another option is to use a dashboard switch as an enable for an outside switch for PTO 2 using the PTO 1 digital pin as an output.

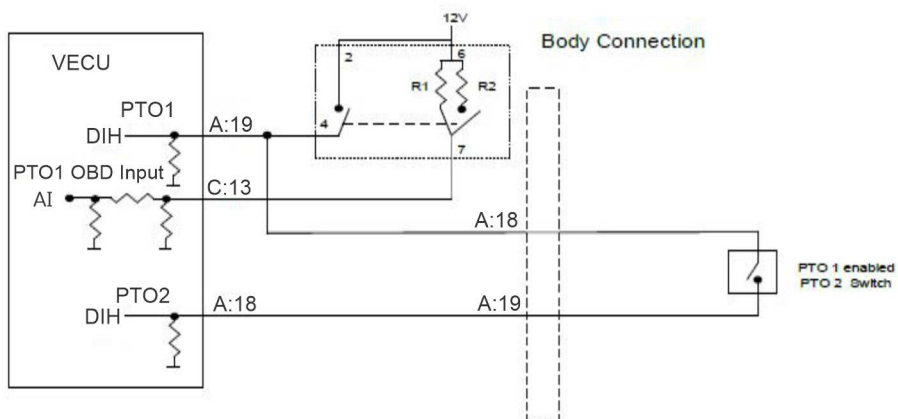

T3180151

However, where this is not practical, a provided Switch Interface Box (SIB) can be used that will allow these inputs to work with conventional open/close switches to 12V.

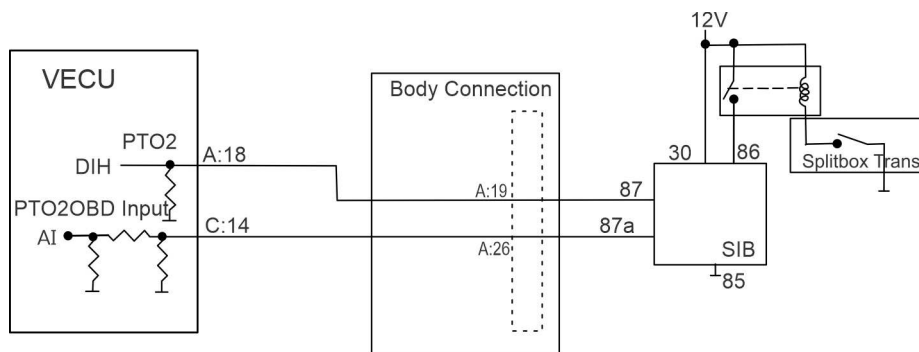

T3180152

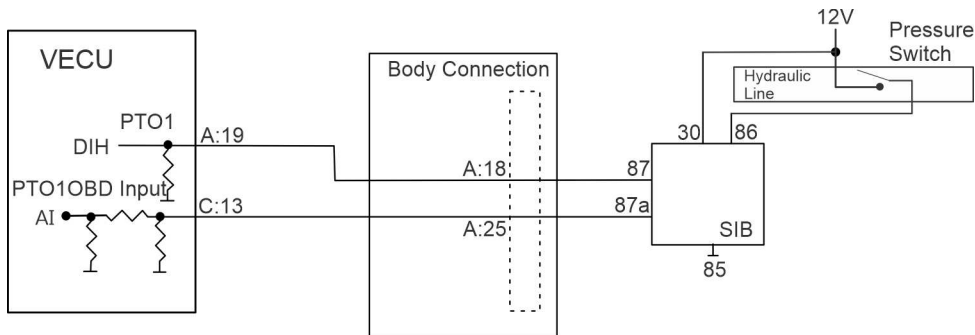

T3180153

Please check with Body Builder Support (877-770-7575) if the above options are not adequate.



T3166534

The SIB switch relay kit part number is 23941264.

Mating Connector Parts for SIB Switch

Description	Quantity	Delphi Part Number	Mack Part Number
Connector	1	12110539	23498540
Terminal	5	12129409	85111011
Seal	5	12015323	1348670
Lock	1	12052834	8397456
Secondary lock	1	12110540	24015094

BodyLink III

BodyLink III is the standard Mack Granite straight truck body builder electrical interface. It consists of a 29-pin electrical quick-connector and grounding stud mounted just under the rear of the cab (near BOC). BodyLink III includes an electrical pin-out label. Also available with BodyLink III is a cab pass-thru between the seats. Note that the carpeting or floor mate is not cut at the factory to avoid unnecessary noise if not used. Also available is a 'BodyLamp' dashboard light to indicate typically when the dump body is elevated. This lamp is activated via pin #17 when grounded. Also available with BodyLink III is assignable (can be labeled) dashboard switches. These switches output via pins 8 to 14 on the BodyLink III connector. A female connector and pins are included with BodyLink III, typically supplied in the cab with the sales and service literature packets.

Note: The BodyLink III BOC connector is supplied with the mating connector housing and terminal pins from the factory. If additional pins or connectors are required, they can be purchased from your local Mack Dealer. The connector housing is 25024037 and the terminal kit is 21750652.

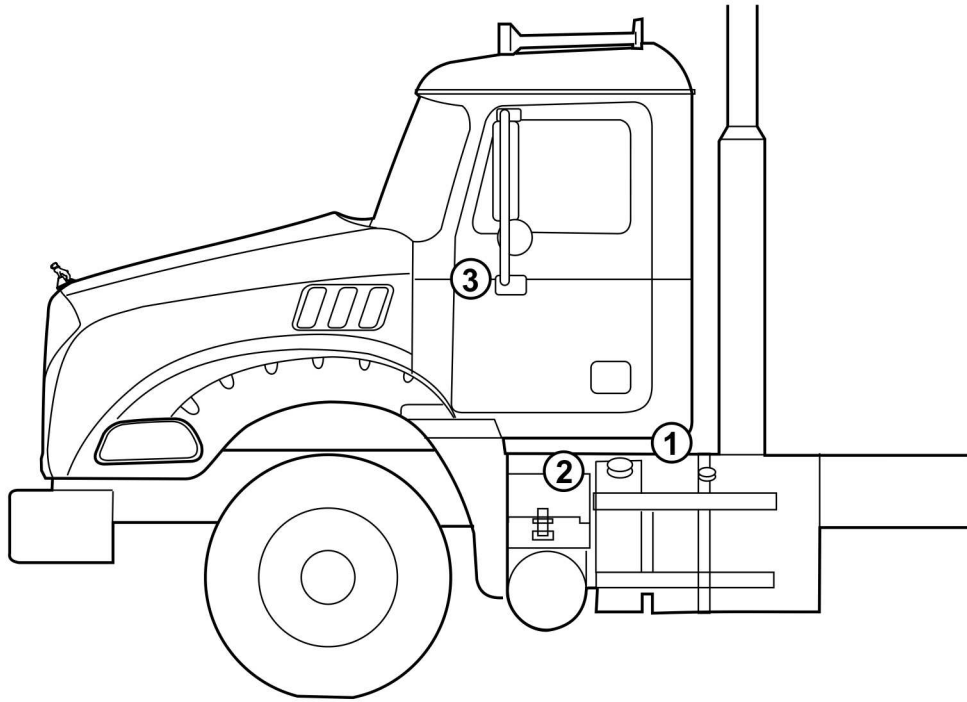

W3084959

Fig. 9 Granite BodyLink III Components

- 1 BodyLink III Connector
- 2 Pass-Thru
- 3 Switch

There is a new display in Co-Pilot to alert the driver that the body is up or out of position.



W8136998

Fig. 10 Body Raised Out of Position

Order Codes for Body Connections (Granite BodyLink III)

Item	Order Code	Model	Status	Description
BodyLink III w/Cab Pass-Thru	B83-0025	Granite and MHD Trucks	Standard	29-pin under-cab connector, BOC label, female connector, cab pass-thru.
BodyLink III w/o Cab Pass-Thru	B83-0026	Granite and MHD Trucks	Optional	Same as above without cab pass-thru.
Body Position Indicator Screen (Co-Pilot)	DIL-BOOP	Granite and MHD Trucks	Standard w/B83-0025B83-0026	Co-Pilot Warning Screen
Six (6) Assignable Body Builder Switches	AUXSW-6B	Granite and MHD Trucks	Optional	Six (6) assignable dashboard rocker switches w/ lenses (5 on-off, 1 momentary)

Notes

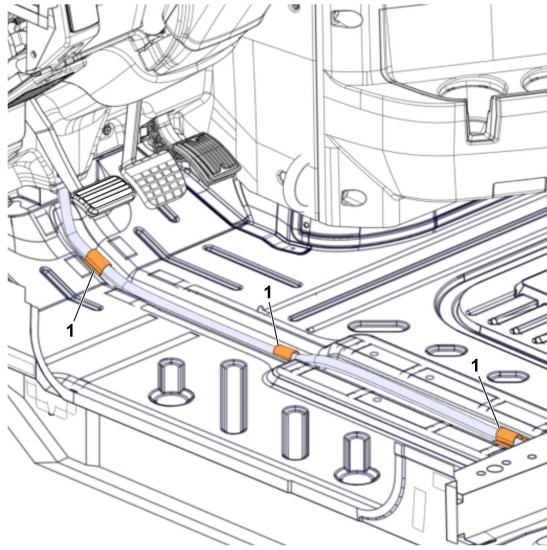

W3092527

Fig. 11 Granite BodyLink III Routing Beneath Driver's Seat

- 1 Rubber Adhesive Tape

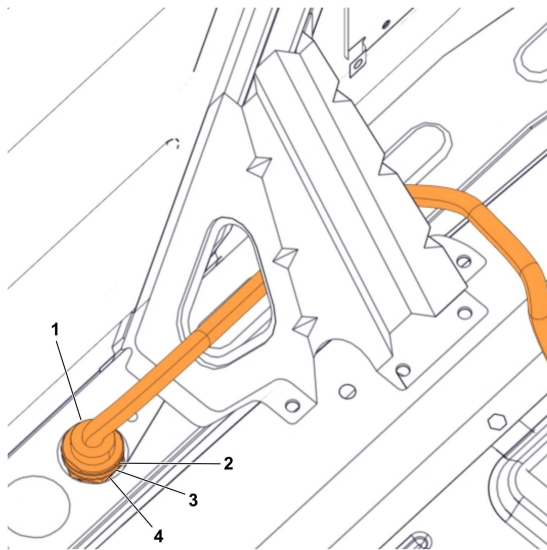

W3092528

Fig. 12 Granite BodyLink III Cab pass-through and Connector

- 1 Body Builder Harness
- 2 Gasket
- 3 Spacer
- 4 Nut, Panel

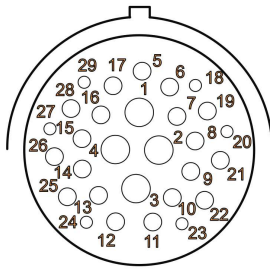

W3064928

Fig. 13 Granite BodyLink III 29-pin Connector, Wire Insertion Side of Connector.

Body Link III

Mating Connector Part : 25024037

Terminal Kit Part : 21750652

Pin Chart for Granite BodyLink III 29-pin Connector

Pole	Description
1	Battery power (30A)
2	Ignition power (30A)
3	Stop lamp
4	Tail lamp
5	Reverse signal
6	LH turn
7	RH turn
8	AUX switch #1 (IGN)
9	AUX switch #2 (BATT)
10	AUX switch #3 (IGN)
11	AUX switch #4 (IGN)
12	AUX switch #5 (IGN)
13	AUX switch #6 (DOWN)
14	AUX switch #6 (UP)
15	Parking brake
16	NEUTRAL SIGNAL
17	Indicator switch (body lamp)
18 (12v positive)	PTO #1 – CA29
19 (12v positive)	PTO #2 – CB7
20 (12v positive)	Speed control ON/OFF
21	BB J1939 +
22	BB J1939 -
23 (12v positive)	Speed control SET/DECEL
24 (12v positive)	Speed control RESUME/ACCEL

Pole	Description
25 and 26	-
27	LH Turn/Stop
28	-
29	RH Turn/Stop

Auxiliary Switch Locations (Cab)

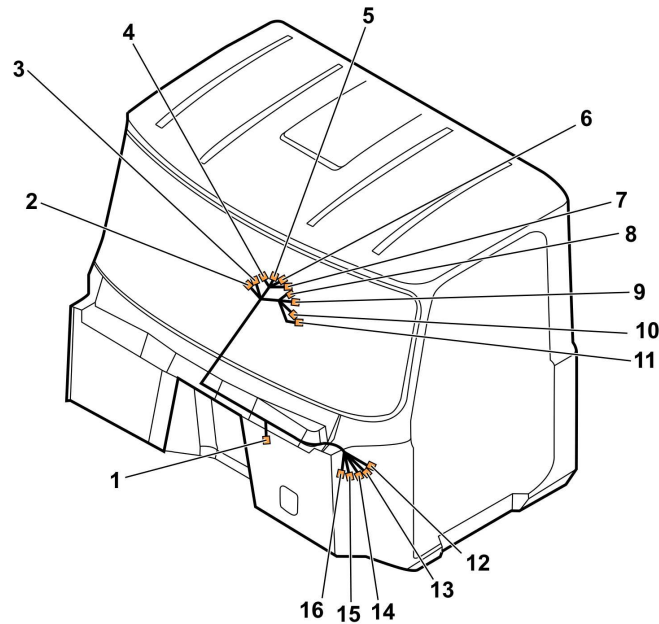

W3099971

Connector	Wire ID	Description
1	IGN_SP11 ¹	Spare Ignition, Switch 4
2	-	-
3	ILLUM_OPT	Optional Illumination Connector
4	S026B	Switch 3, Ignition
5	S026C	Switch 4, Ignition
6	S026D	Switch 5, Ignition
7	S027B	Switch 6, Battery
8	ING_SP12	Spare Ignition, Switch 3
9	BAT_SP3	Spare Ignition, Switch 6
10	IGN_SP10 or BB_LP ²	Spare Ignition, Switch 5
11	BB_LP_6SW_PLUG	-
12	MISC_2	Output, Switch 3
13	MISC_3	Output, Switch 4
14	MISC_4	Output, Switch 5

Connector	Wire ID	Description
15	MISC_5	Output, Switch 6
16	MISC_6 ³	Output, Switch 6

1 If body builder wiring is specified, attach body builder wiring as follows: MISC_2 to BBSP_2, MISC_3 to BBSP_3, MISC_4 to BBSP_4, MISC_5 to BBSP_5, MISC_6 to BBSP_6. Otherwise, band all MISC connectors behind ABC panel.

2 If body builder wiring is specified, attach body builder wiring as follows: MISC_2 to BBSP_2, MISC_3 to BBSP_3, MISC_4 to BBSP_4, MISC_5 to BBSP_5, MISC_6 to BBSP_6. Otherwise, band all MISC connectors behind ABC panel.

3 Connect spare ignition and battery connector to main cab harness as follows: IGN_SP12 to IGN_SP1 or IGN_SP9, IGN_SP11 to BAT_SP4, IGN_SP10 to IGN_SP8 or BB_LP_PLUG, and BAT_SP3 to IGN_SP3.

Power Connections

Some judgment must be made for powering body equipment with the following trade-offs:

Ignition power – Will power off during engine crank, which may cause faults or other effects if power supplies inputs used by ECUs on EMS power. May also be disconnected for low voltage disconnect.

EMS Connections – Available with key off but may effect starter performance or be affected by starter power fluctuations.

Battery Connections – Always available but will contribute to key off battery drain as well as effect, and be affected by, starter as above.

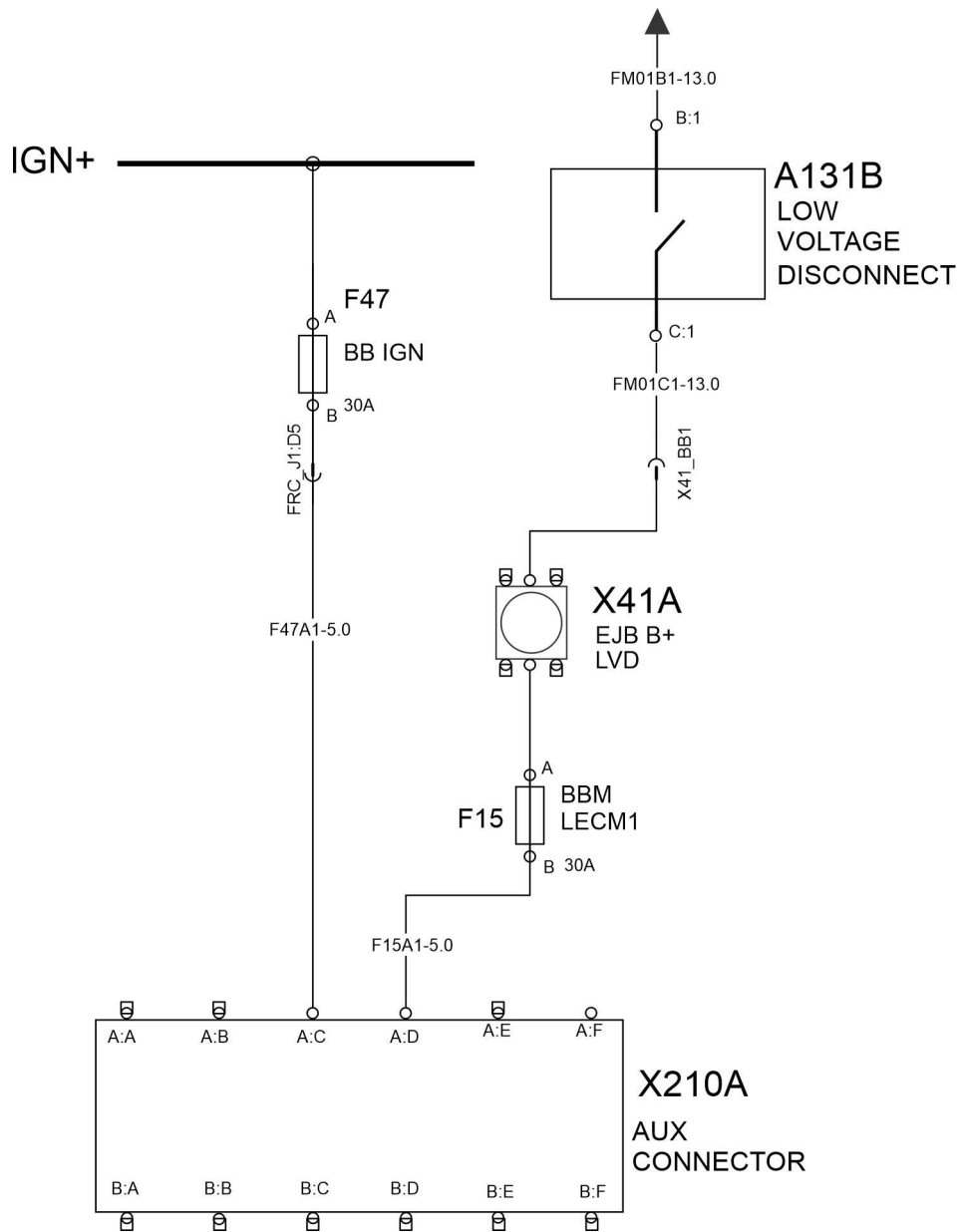

T3168145

Fig. 14 Power Connections, Conventional GEN II Trucks (AN/PI/GR)
Interrupted at ENGINE CRANK and LOW VOLTAGE DISCONNECT.

Notes

Conventional Auxiliary Switches

Conventional Trucks have the option to place dashboard switches connected to outputs in the outside body connector.

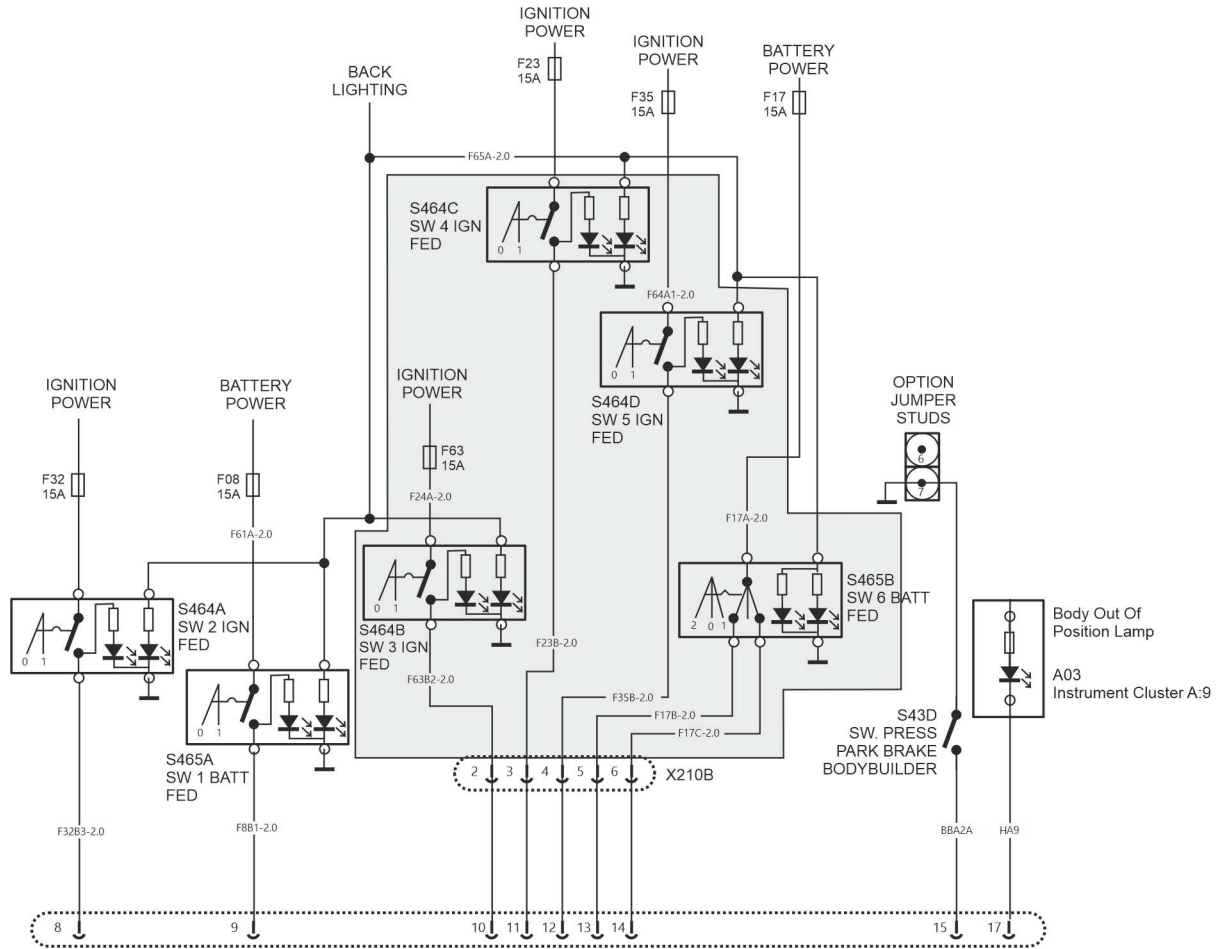

T3189430

Fig. 15 Conventional Auxiliary Switches

Notes

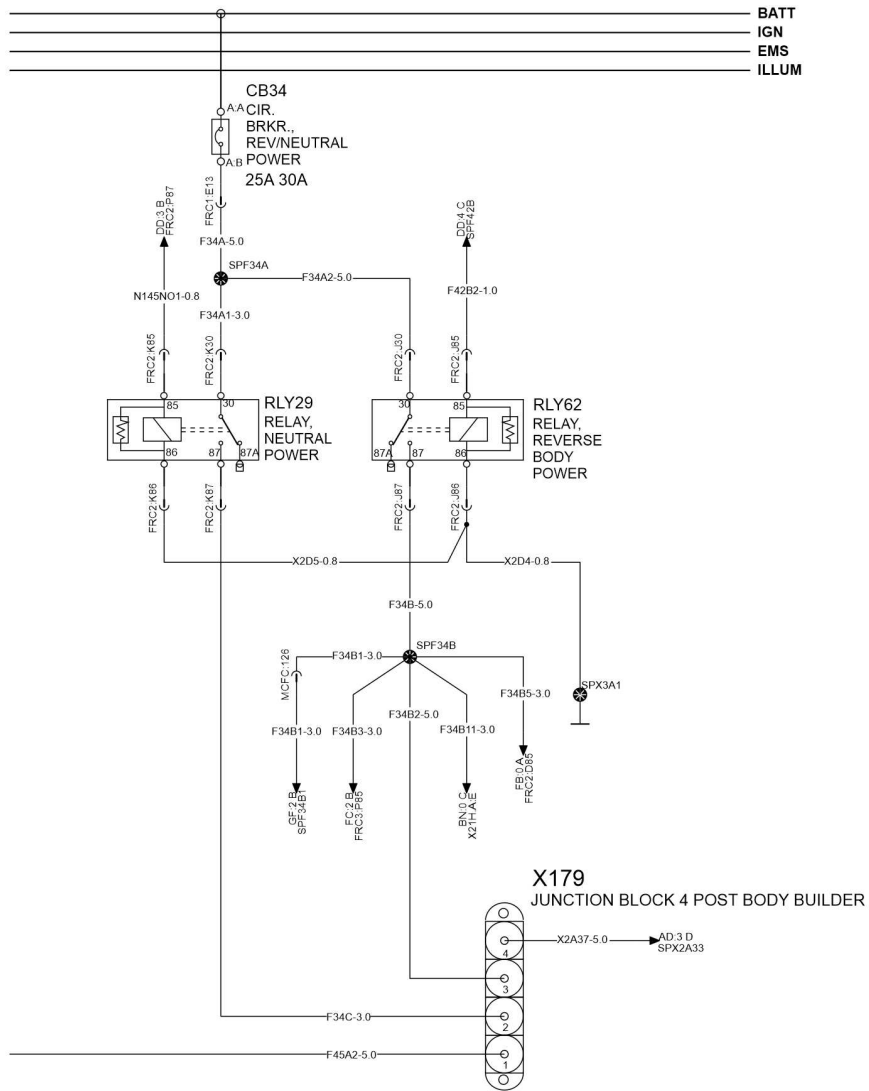

T3190570

Fig. 16 Conventional — Reverse & Neutral Power

Notes

Body Builder Connections

Cab

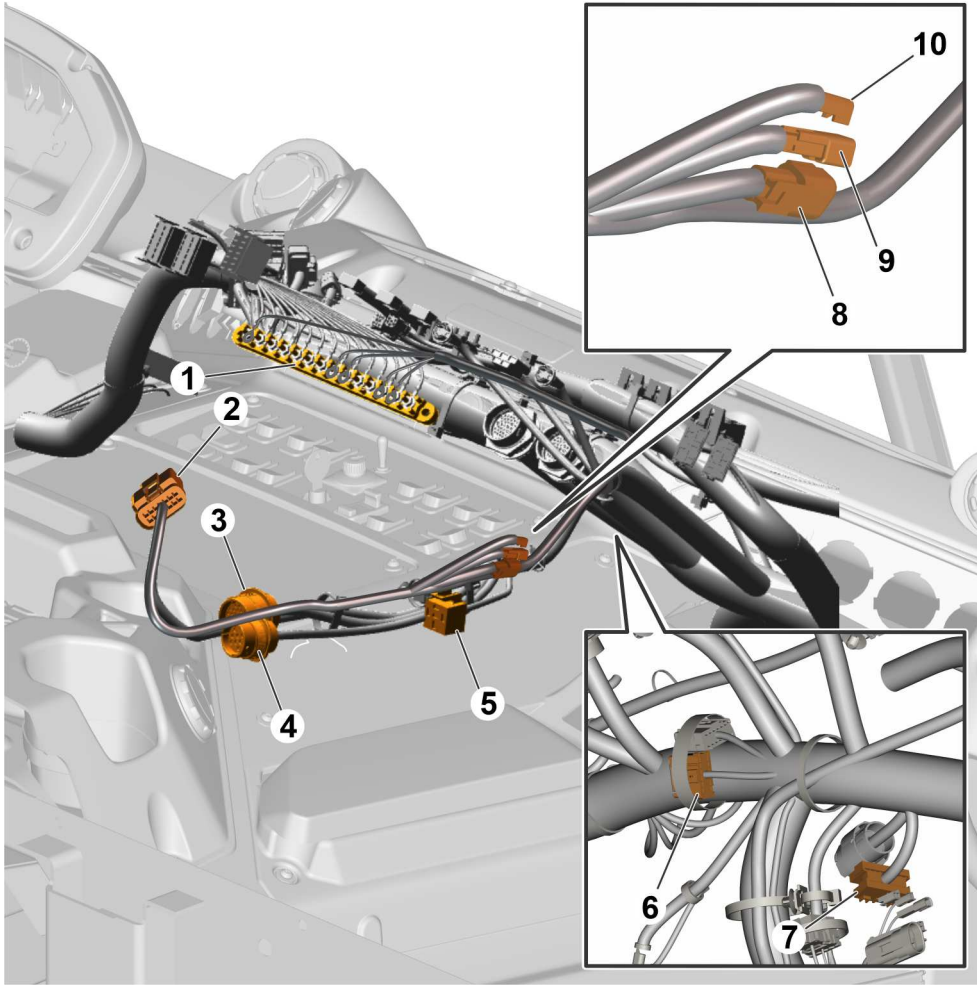

T3173643

1	Body builder junction block (X175)	6	Split Connector, Ground (X111)
2	Vehicle accessory connector (RP1226 (A175A))	7	DCL connector (X21B)
3	RP170 power (X21H)	8	Termination resistor (R08G)
4	RP170 powertrain (X21F)	9	BBM-1939 socket
5	Relay (RLY95)	10	BBM-1939 plug

Chassis

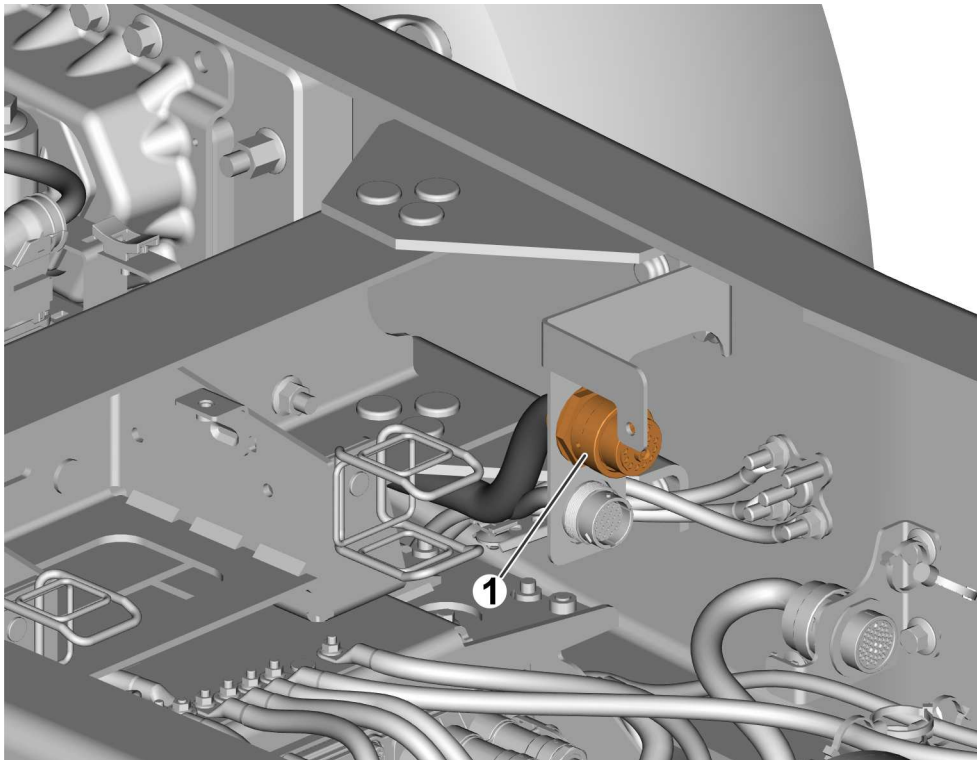

T3174248

1 RP170 lighting (X21G)

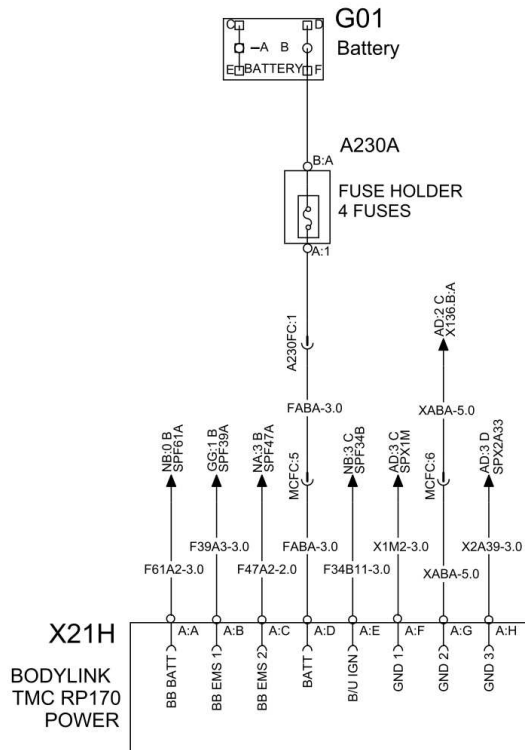

T3190571

Fig. 17 Body Builder Power & Ground LR RP170

Notes

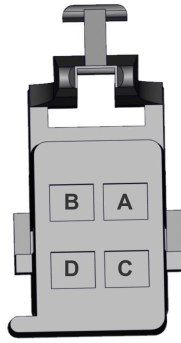

T3174266

Fig. 18 DCL Connector (LR, TE) or Connector X21B (LR)

DCL Connector (LR, TE) or Connector X21B (LR)

Pin	Description
A	VECU switch input
B	Ground
C	Spare switch
D	Open

Allison Connections

TE, LR RP170 has many Allison connections included. Conventional Body Link does not. However, all trucks with Allison Transmissions include a connector (X06D) to access Allison functions directly.

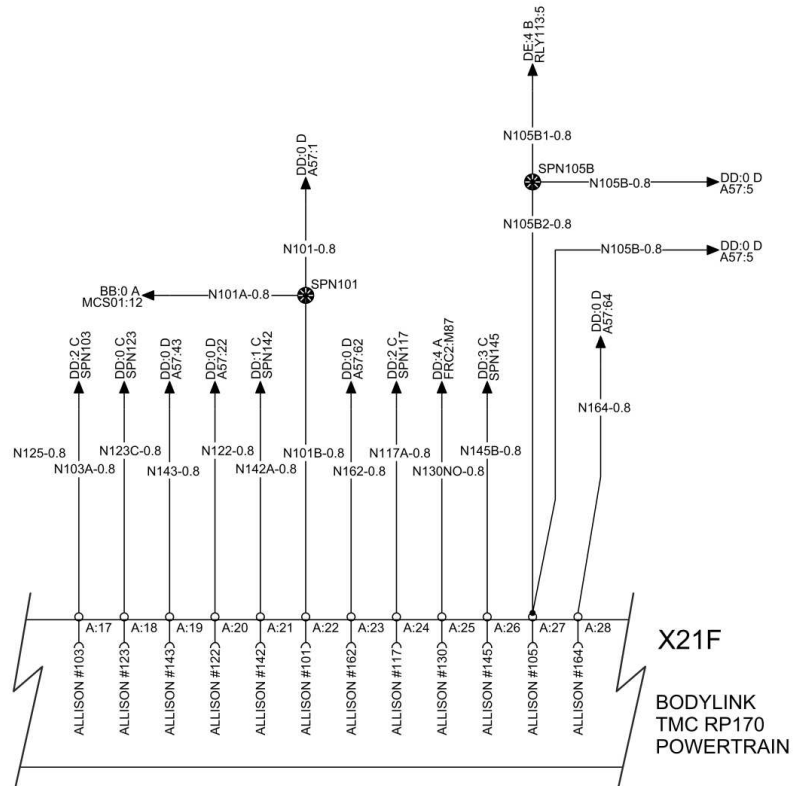

T3190601

Fig. 19 Allison Connections — TE, LR

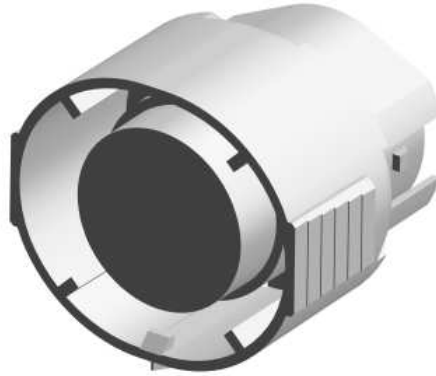

T3185349

Fig. 20 Allison X06D connector

Note: For truck built before 12/2022

Description	Part number
Allison X06D connector	20897253
Terminal	7526-12084912

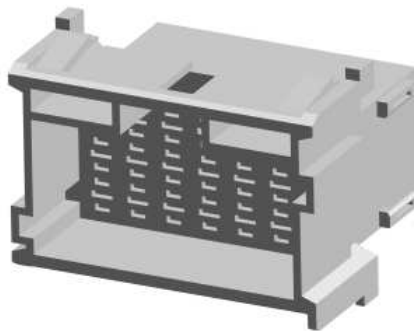

T3185348

Fig. 21 Allison X06D connector

Note: For truck built on and after 12/2022

Description	Part number
Allison X06D connector	3987483
Terminal	978295

Notes

PTO and Engine Speed Control Connections

TE and LR have several specific wiring options for PTO that don't necessarily affect engine speed control. However the RP170 connection offers access to inputs to affect engine speed control based on PTO activation or other equipment inputs.

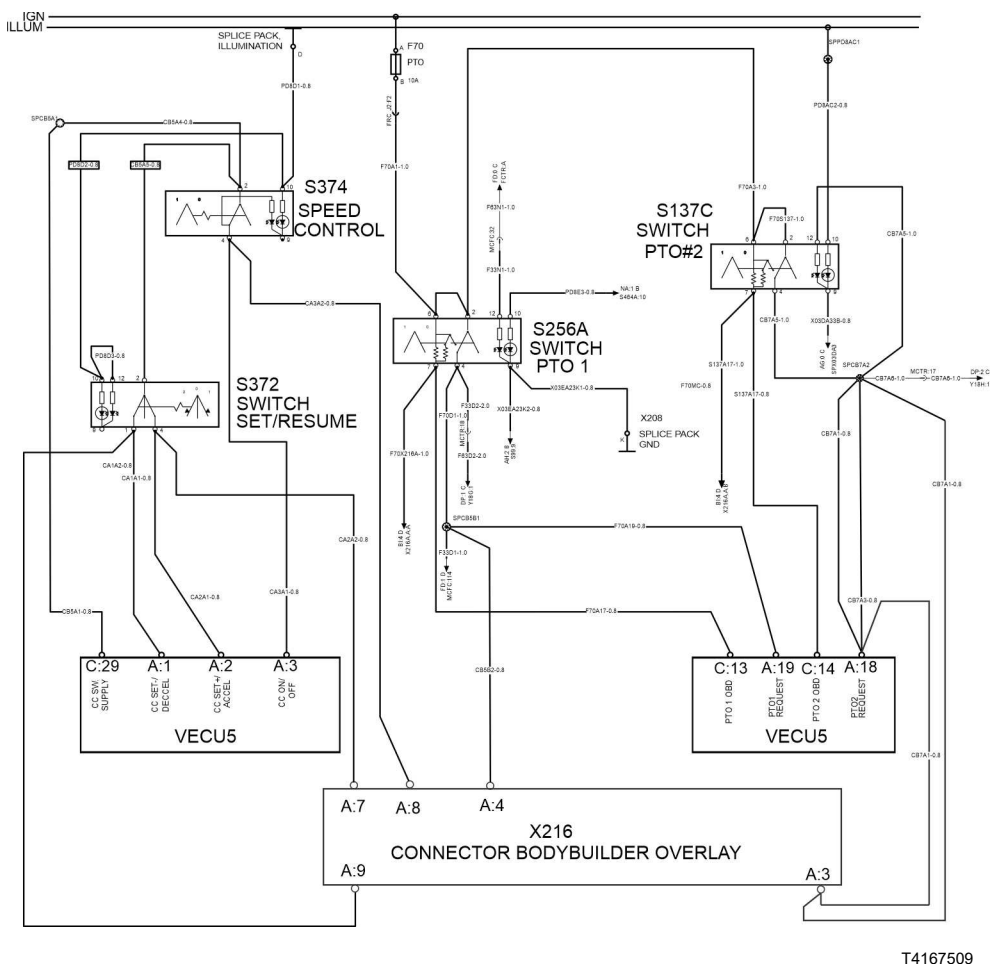
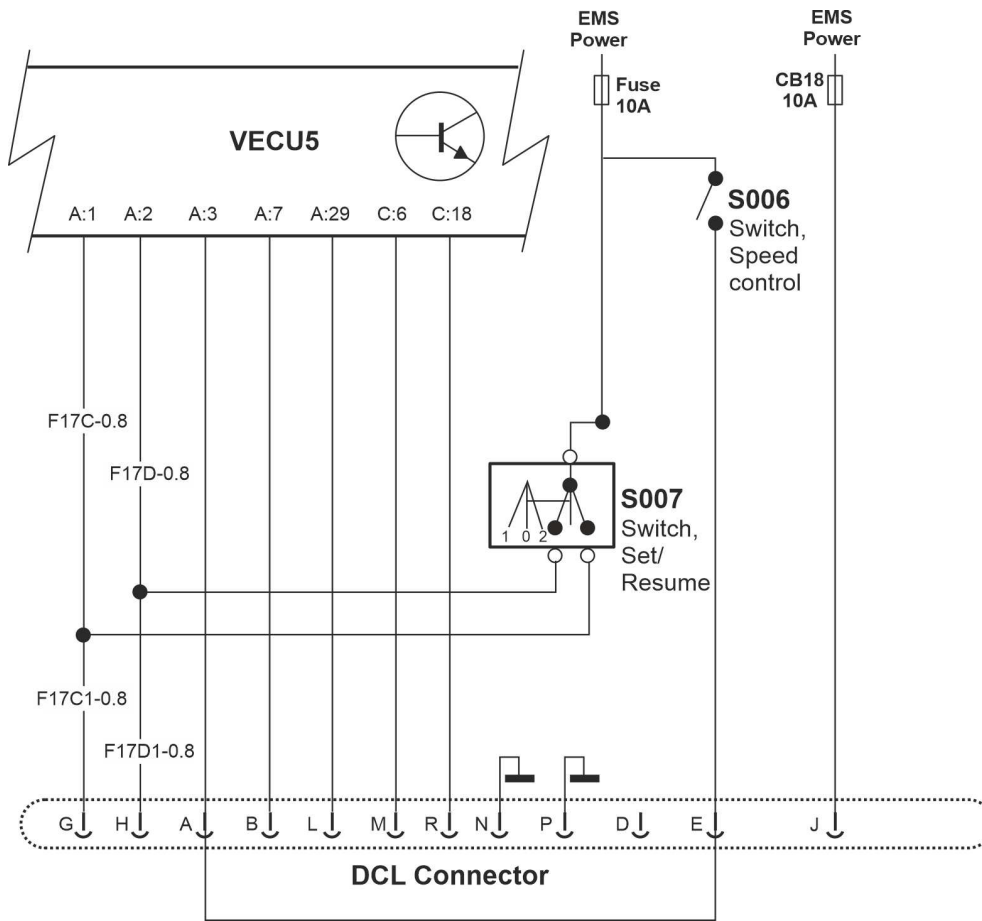
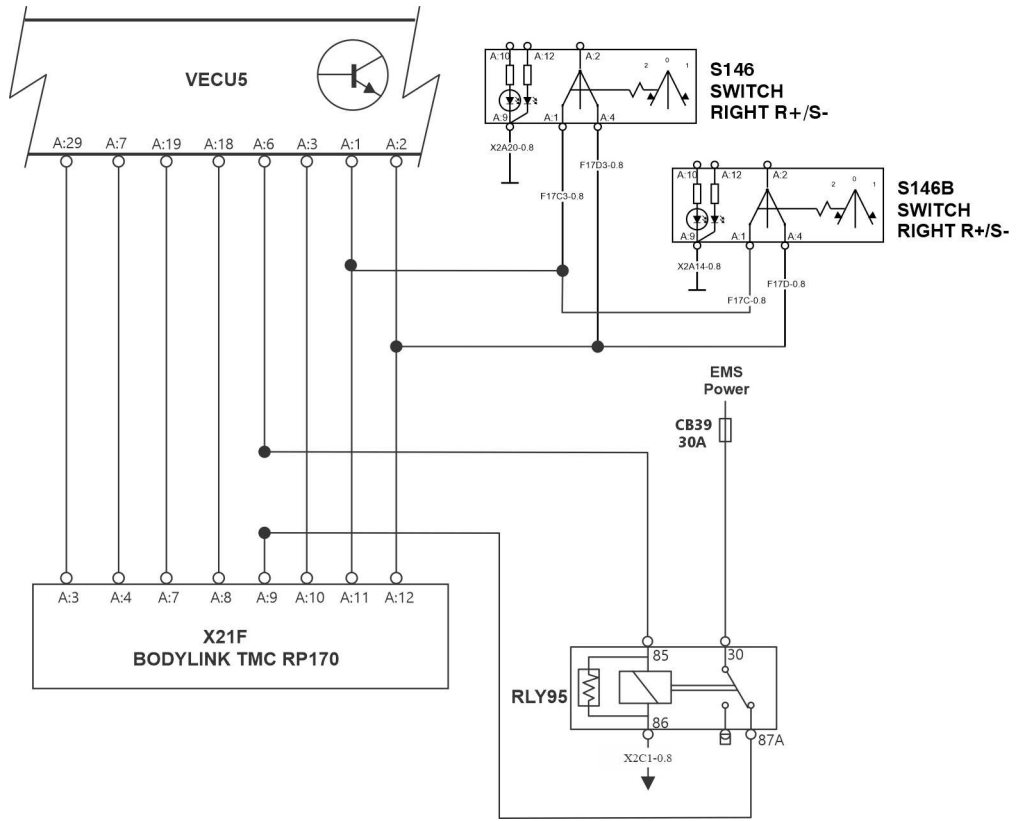

Fig. 22 PTO & Engine Speed Control Connections, Mack Conventional



T3190602

Fig. 23 PTO & Engine Speed Control Connections, TE



T4167511

Fig. 24 PTO & Engine Speed Control Connections, LR

Lighting Connections

TE, LR RP170 has lighting connections in a separate BOC connector whereas conventional has lighting connections in the Body Link III connector, which is also BOC. These are nominally lighting outputs but can also be used for control.

Note: Neutral and Reverse are also in the TE, LR RP170 connector.

Note: Refer wiring diagram section of Mack Conventional- VECU 5, Mack TE, VECU 5 and Mack LR, VECU 5 for the wiring schematics of lighting connection.

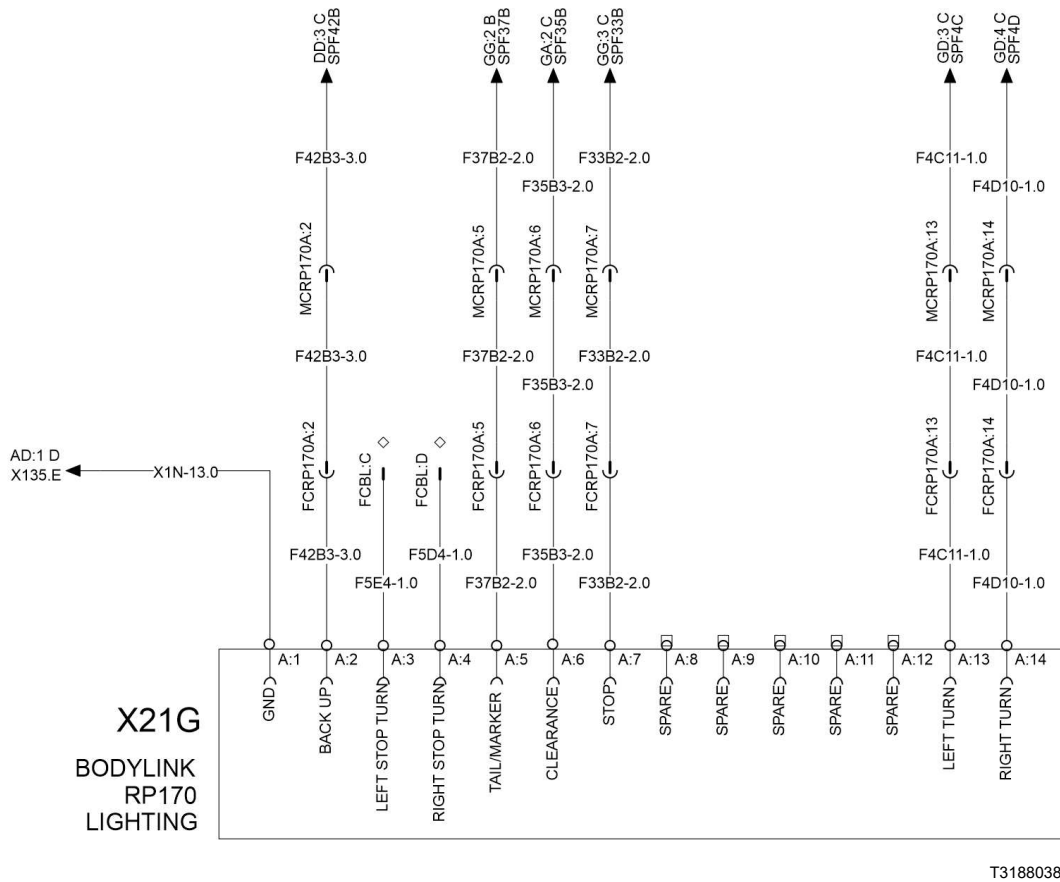
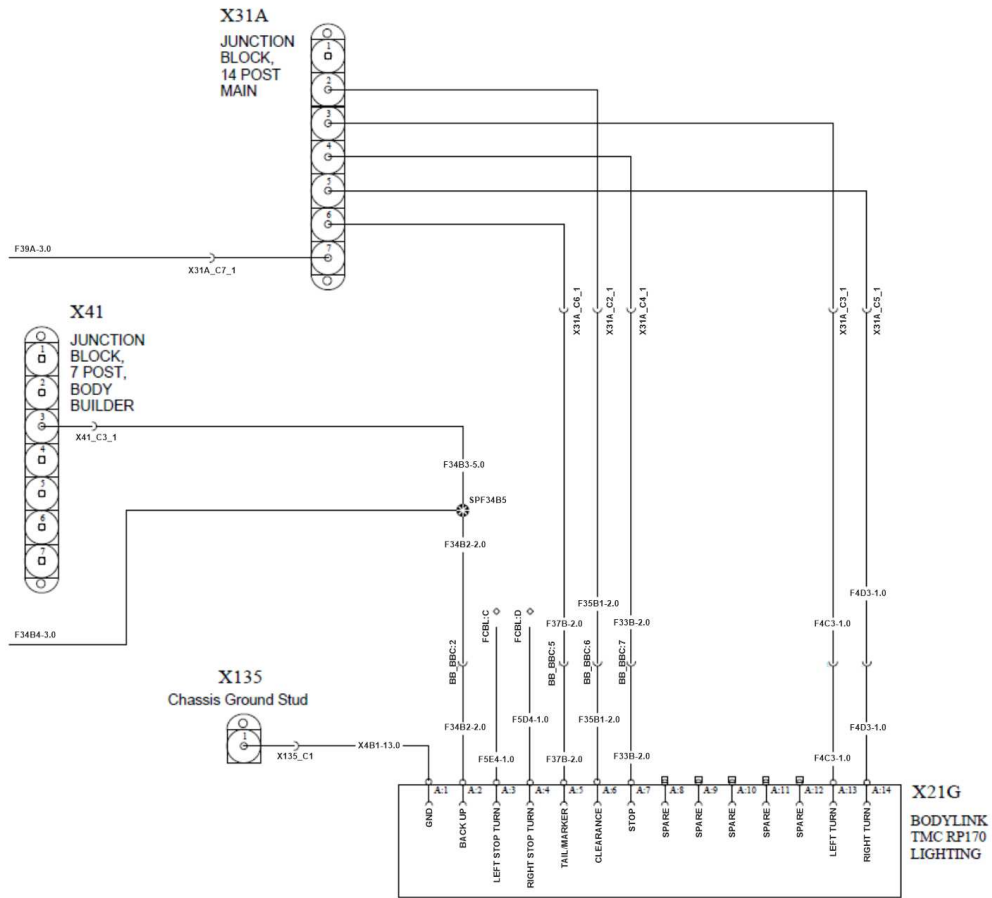

Fig. 25 LR Lighting Connections



T3199293

Fig. 26 TE Lighting Connections

Notes

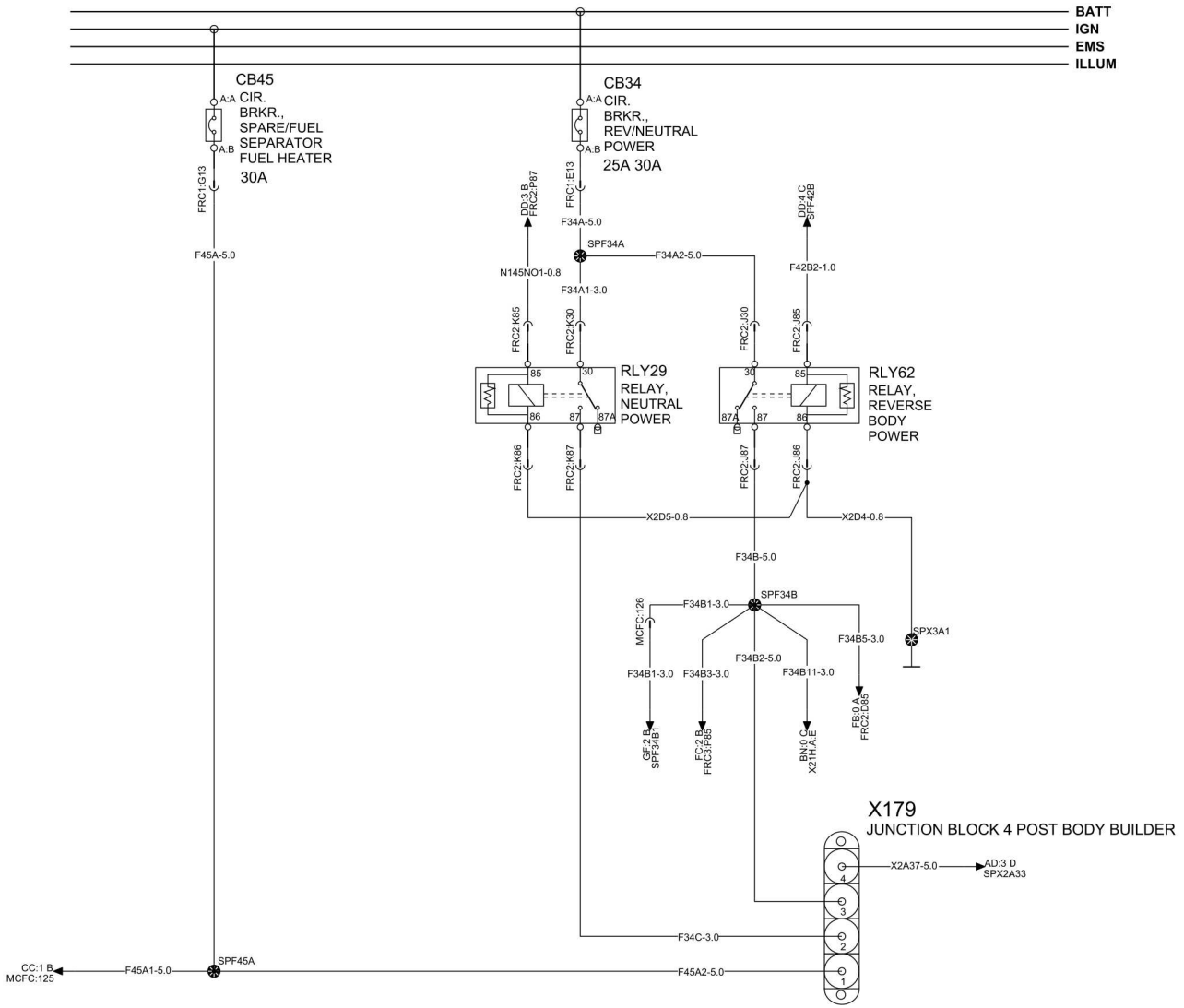

T3190605

Fig. 27 LR Lighting Connections – Reverse and Neutral

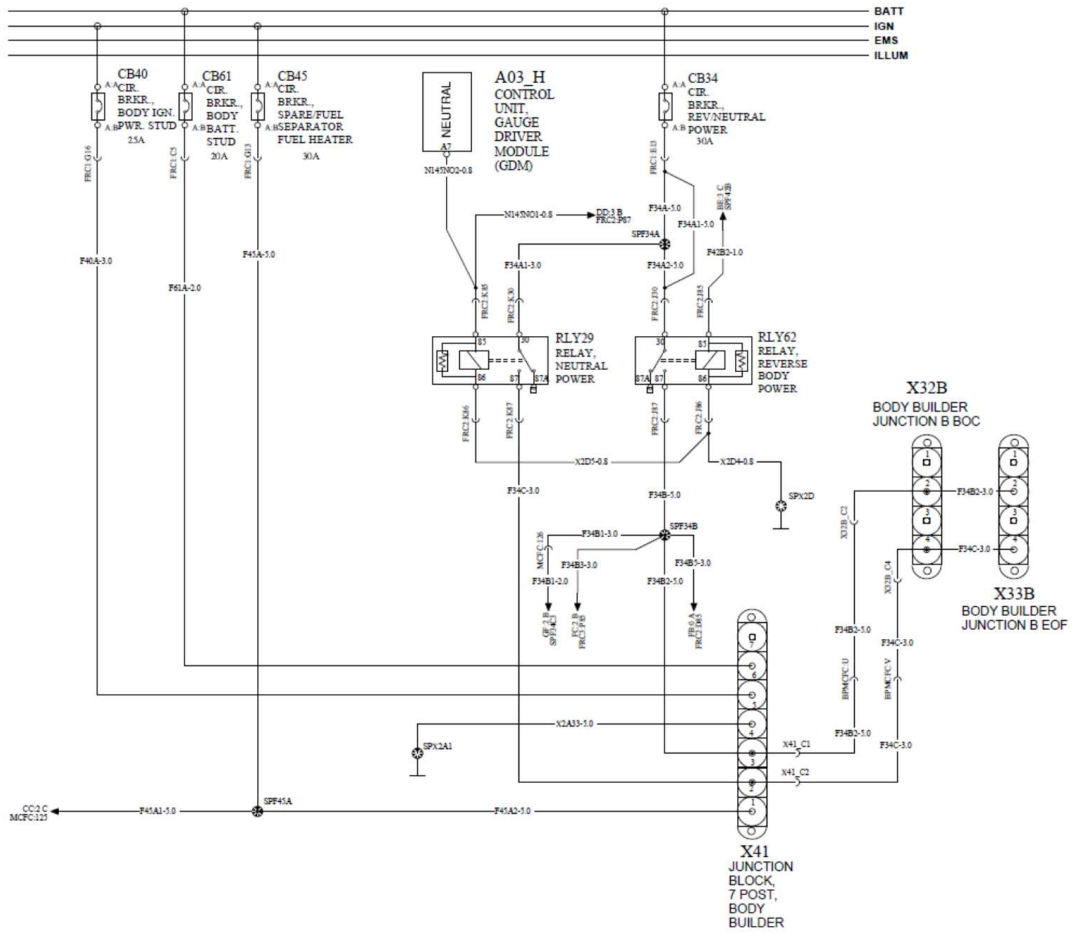

T3199294

Fig. 28 TE Lighting Connections

RP170A Refuse Related Chassis to Body Interface Connectors



W3136995

Fig. 29 RP170A Cab 31–Cavity Connector

Cavity Assignments for TE/MRU/LR/LEU 31-cavity Body Builder Connector

Cavity	LR Wire ID	TE Wire ID	Description
1	G02R1	G02R1	(16ga) rpm
2	OPEN	F24B1	(16ga) Reverse signal
3	CA18	F17M3	(18ga) PTO#2
4	CA19	CB7	(18ga) PTO#1
5	DL5HB2	DL5HB2	(18ga) BBM J1939H
6	DL5LB2	DL5LB2	(18ga) BBM J1939L
7	CA7	CB21	(18ga) Spare SW3/PTO#3
8	CA29	CA17	(18ga) Spare SW4/PTO#4
9	F39B	F56A1	(16ga) IGN POWER
10	F17E3	F17E4	(18ga) Cruise control ON/ OFF
11	F17C4	F17C1	(18ga) Deceleration
12	F17D4	F17D1	(18ga) Acceleration
13	X3B8	BBA13A1	(18ga) PB switch
14	OPEN	31A19	Spare
15	N130CM2	N130CM3	(18ga) Trans EMS power
16	N125	N125	0.8MM, (18ga) SPEEDO
17	N103A	N103A	(18ga) Ground signal
18	N123C	N123A	(18ga) Split shaft or neutral at stop
19	N143	N143	(18ga) PTO request

20	N122	N122	(18ga) Pump mode type
21	N142A	N142A	(18ga) Auxiliary hold
22	N101B	N101	(18ga) Range inhibitor
23	N162	N162	(18ga) Retarder temperature
24	N117A	N117A	(18ga) Auto neutral
25	N130NO	N130NO	(18ga) PTO enable
26	N145B	N145B	(18ga) Range indicator
27	N105B	N105	(18ga) Overspeed indicator
28	N164	N164A	(18ga) Transmission temperature
29	N145NO	N145NO	(18ga) Neutral signal
30	F18A	F18A1	(18ga) IGN signal
31	F17B2	OPEN	Left/Right Status



W3136996

Fig. 30 RP170A Chassis 14-Cavity Connector

Cavity Assignments for TE, LR 14-cavity Body Builder Connector

Cavity	Wire ID for LR	Wire ID for TE	Description
A:1	X1N	X4B1	(6ga) Ground to frame
A:2	F42B3	F34B2	(14ga) Back up
A:3	F5E4	F5E4	(16ga) Left stop turn
A:4	F5D4	F5D4	(16ga) Right stop turn
A:5	F37B	F37B	(14ga) Tail/marker
A:6	F35B3	F35B1	(14ga) Clearance
A:7	F33B	F33B	(14ga) Stop
A:8	-	-	Spare
A:9	-	-	Spare
A:10	-	-	Spare
A:11	-	-	Spare
A:12	-	-	Spare
A:13	F4C11	F4C3	Left turn
A:14	F4D10	F4D3	Right turn



W3136997

Fig. 31 RP170A Chassis 8-Cavity Connector

Cavity Assignments for TE/MRU/LR/LEU 8-cavity Body Builder Connector

Cavity	Wire ID	Description
A	F61A2	(12 GA) Wire fed from CB61 (BATT+)
B	F39A3	(12 GA) Wire fed from CB11
C	F47A2	(14 GA) Wire fed from CB47
D	FABA	(12 GA) Wire fed from A230A fuse holder
E	F34B11	(12 GA) Wire fed from RLY62 (FRC2: J87)
F	X1M2	(12 GA) Wire fed from ground X1_C2
G	XABA	(10 GA) Wire fed from ground stud X136
H	X2A39	(12 GA) Wire fed from ground X4_C2

Notes

LR Work brake

The Mack has a work brake, which operates pneumatically like a service brake. It is also tied into Allison inputs to effect a forced neutral. The Allison also has some conditions to allow switching driving positions so that loss of throttle and transmission control don't happen while moving.

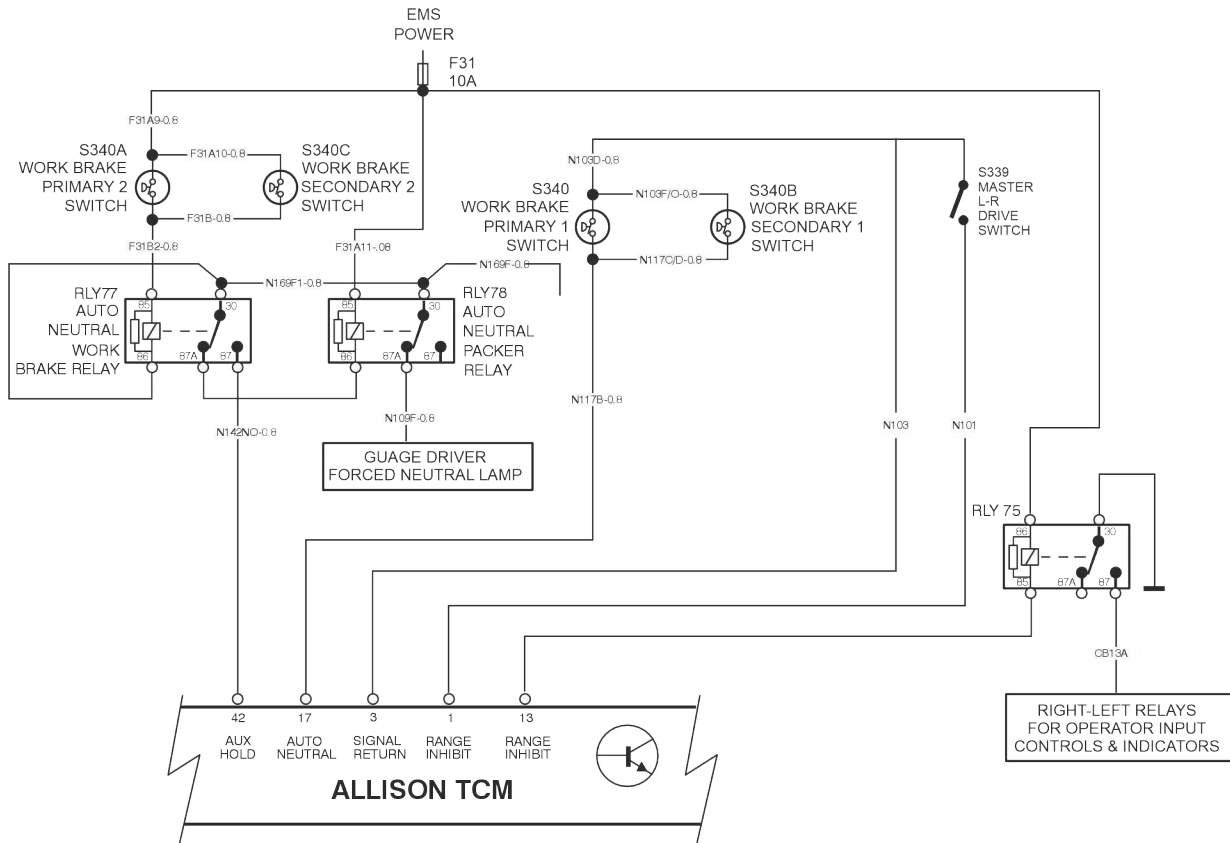

T3190606

Fig. 32 LR Work brake

Notes

Summary

Figure 31 shows examples of what the control pins could be used for in an application. The PTO inputs are programmable and can affect a conditional output, engine ramp, engine limits, etc. See programming section for details. Note that full safety evaluation of the system should be carried out. I.E., adequate interlocks should be programmed or wired, so that the engine will not accelerate in unintended situations. Interlocks can be done by powering switches using switched power (for example neutral power) or by software parameters or both. For example, most applications should only have the engine ramp using body controls when the parking brake is on and the transmission is in neutral. Exceptions should be carefully considered.

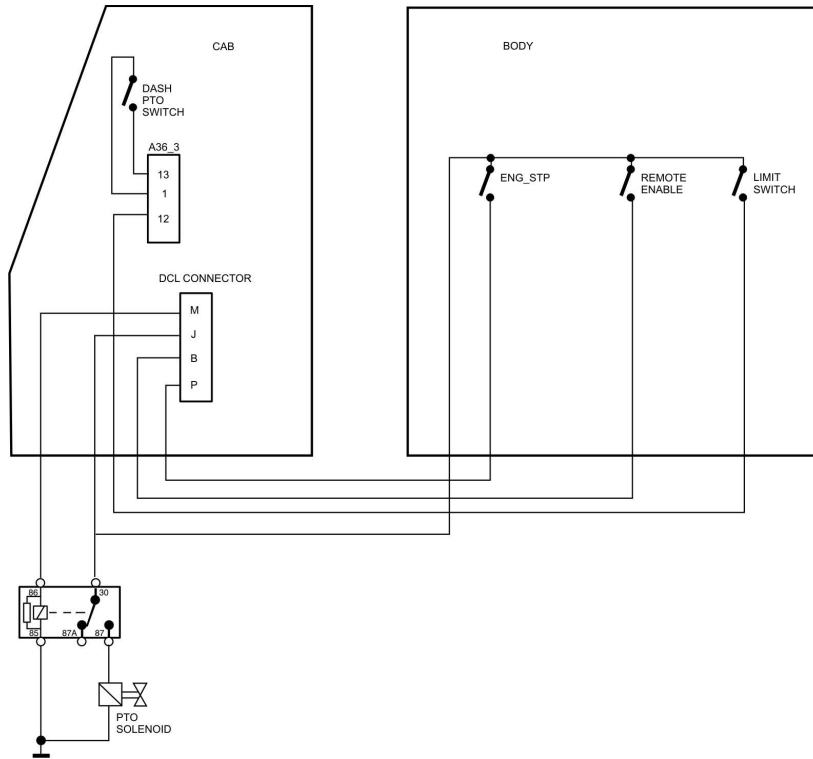

W3113957

Fig. 33 Example TE showing Body Builder supplied wiring for Controls

Notes

Snow Plow with Extra Auxiliary Lamp

Granite (GR), Interior Generation II

Note: Trucks built after November 1, 2020 will not need to install the harness as outlined below. Snow Plow with Auxiliary lamp functions can be programmed with the new LCM software. Check with your local Mack Dealer for details.

Note: Mack Trucks certifies that its vehicles comply with all applicable Federal Motor Vehicle Safety Standards for operation in North America at the time of initial vehicle build; however, Mack Trucks does not guarantee that a given vehicle complies with all individual State and Provincial regulations in the area that the vehicle is being operated. It is the responsibility of the customer and/or its Final Stage Manufacturer to ensure that the complete vehicle is compliant with all local regulations in the geographic area of usage.

With the introduction of the Mack Granite Generation II Interior and its many new options and conveniences over the previous Generation I Interior, a new LCM (Light Control Module) was introduced. This has affected how headlamps and fog lamps can be integrated into a vehicle for operation in different geographic locations as described in the Note.

This document contained the following information, which can be used by customers and their Final Stage Manufacturers to correctly configure headlamps and auxiliary lamps to allow their vehicle to comply with their appropriate State and Provincial regulations:

- Installation Instructions
- Part Number List
- Wiring Diagrams
- Wiring Harness Connection Matrix

Contact Mack Trucks Body Builder Support Group 877-770-7575 or visit "<https://www.macktrucks.com/parts-and-services/support/body-builders/>" for any support.

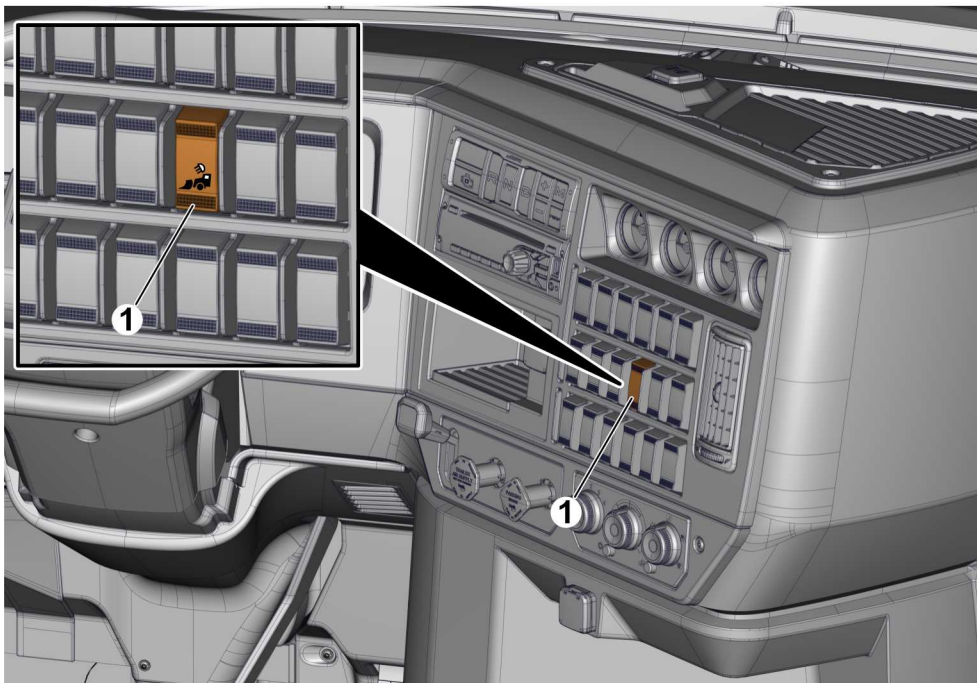

T3161927

1 Auxiliary lamp switch (snow plow)

When a Granite truck is ordered with snow plow parameter set, the user can have fog lamp operational with snow plow low beam.

The snow plow auxiliary lamps are turned on/off using a switch in the dashboard. The stalk is used to switch between the high beam and low beam of snow plow auxiliary lamps.

The truck's fog lamps can be activated only with the snow plow lamps on low beam and turn off when the high beam is activated.

Routing and clipping of snow plow auxiliary light harness

Required parts

No	Part Number	Description	Quantity
1	23783544	Wires (dashboard overlay)	1
2	980464	Cable tie	16
3a	23785656	Wires (dog house overlay)	1
3b	23266504	Wires (EPDM pigtail jumper)	1
4	980464	Cable tie	2
5	84175248	Plate	1
6	25111125	Screw	4
7	20466164	Cable tie	2
8	25095012	Screw	2
9	25109882	Nut	2
10	23837889	Bracket	1
11	25109115	Screw	2
12	20706309	Lock nut	2
13	25110848	Mounting plate	1
14	980464	Cable tie	17
15	23783546	Wires (front chassis overlay)	1
16	980464	Cable tie	9
17	23734646	Wires (auxiliary lamp overlay)	1

Additional needed parts

Part Number	Description	Quantity
23387819	Auxiliary lamps switch	1
25095420	Washer	8
25089433	Nut	4
25092582	Screw	2
84755571	Plate (EPDM cover) Note: EPDM plate has to be changed to allow auxiliary lamp wires to pass through.	1

25171506	Nut retainer Note: Nuts to secure EPDM plate can be reused if not damaged.	6
84755477	Gasket	1

Dashboard overlay

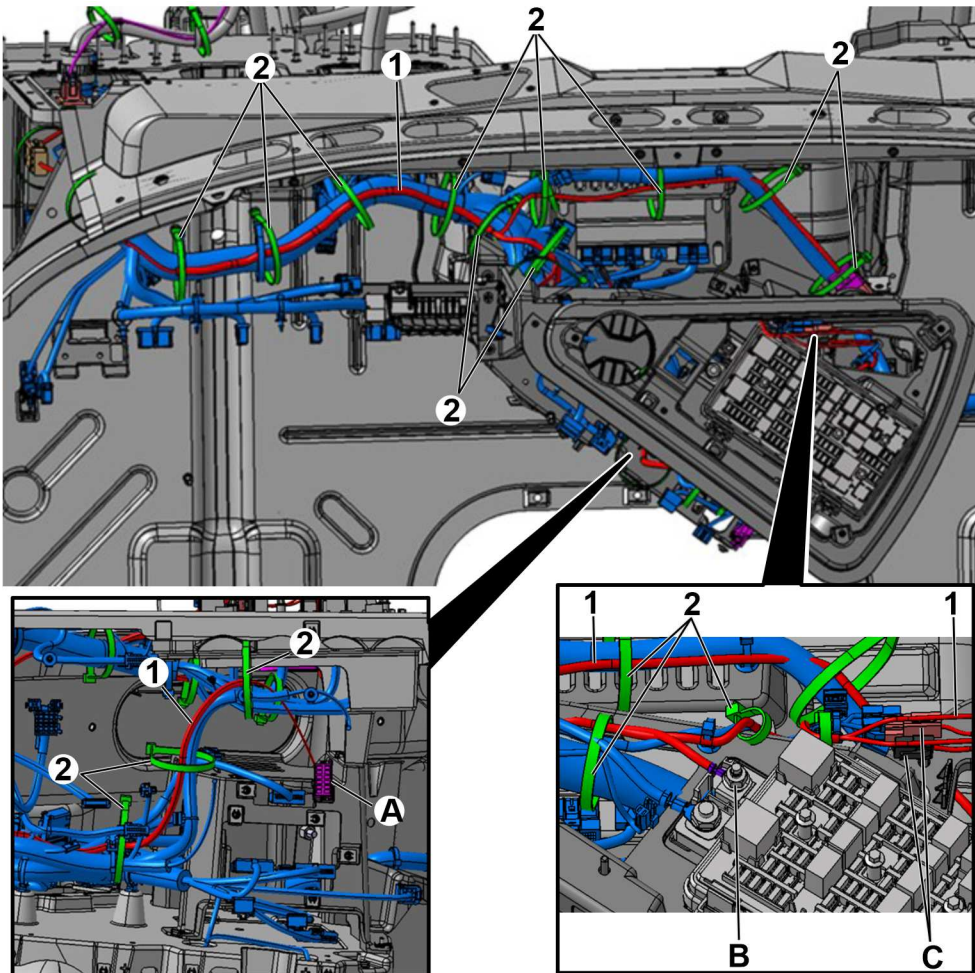

T3161288

A	The snow plow dashboard overlay harness (red) should follow and be cable tied to the main cab harness (blue)
B	Place the X41 ring terminal (labeled X41) on the dashboard overlay harness (red) on the positive stud on the FRC (fuse and relay centre). Torque to 140 in-lbs maximum.
C	Connect the X117_D connector (labeled ignition option) on the dashboard overlay harness (red) to the X117_D connector (labeled ignition option) on the main cab harness (blue). Take the extra X117_D that will be used as a spare ignition connection.
1	Wires (dashboard overlay - 23783544)
2	Cable tie (980464)

Front of dog house

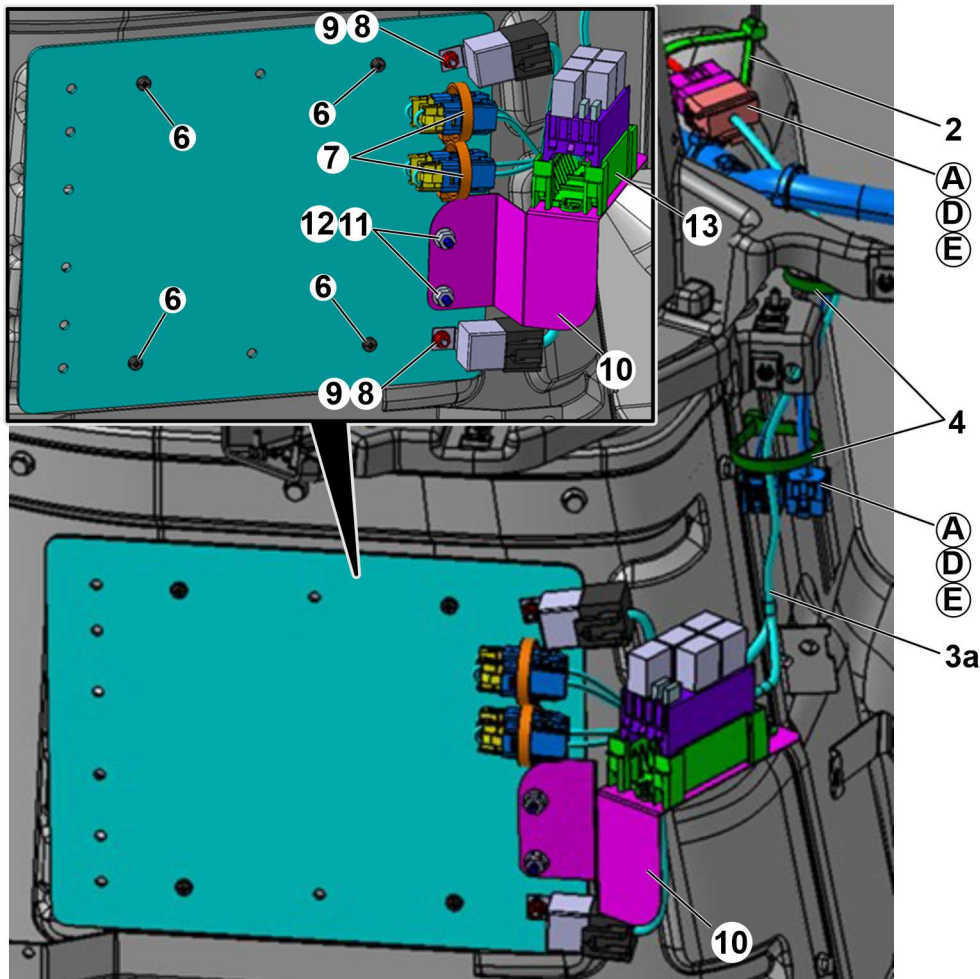

T3161293

A	The snow plow dashboard overlay harness (red) should follow and be cable tied to the main cab overlay harness (blue)
D	The connector labeled "DOG HOUSE" should connect to the dog house overlay harness (green)
E	The connector labeled "DOG HOUSE" should follow the main cab overlay harness (blue) and down to the relay and fuse connector base
2	Wires (dashboard overlay - 23783544)
3a	Wires (dog house overlay - 23785656)
6	Screw (25092582)
7	Cable tie (20466164)
8	Screw (25095012)
9	Nut (25109882)
10	Bracket (23837889)
11	Screw (25109115)
12	Lock nut (20706309)
13	Base connector module (25110848)

EPDMP-A connector on LHS (left-hand side) of the steering column

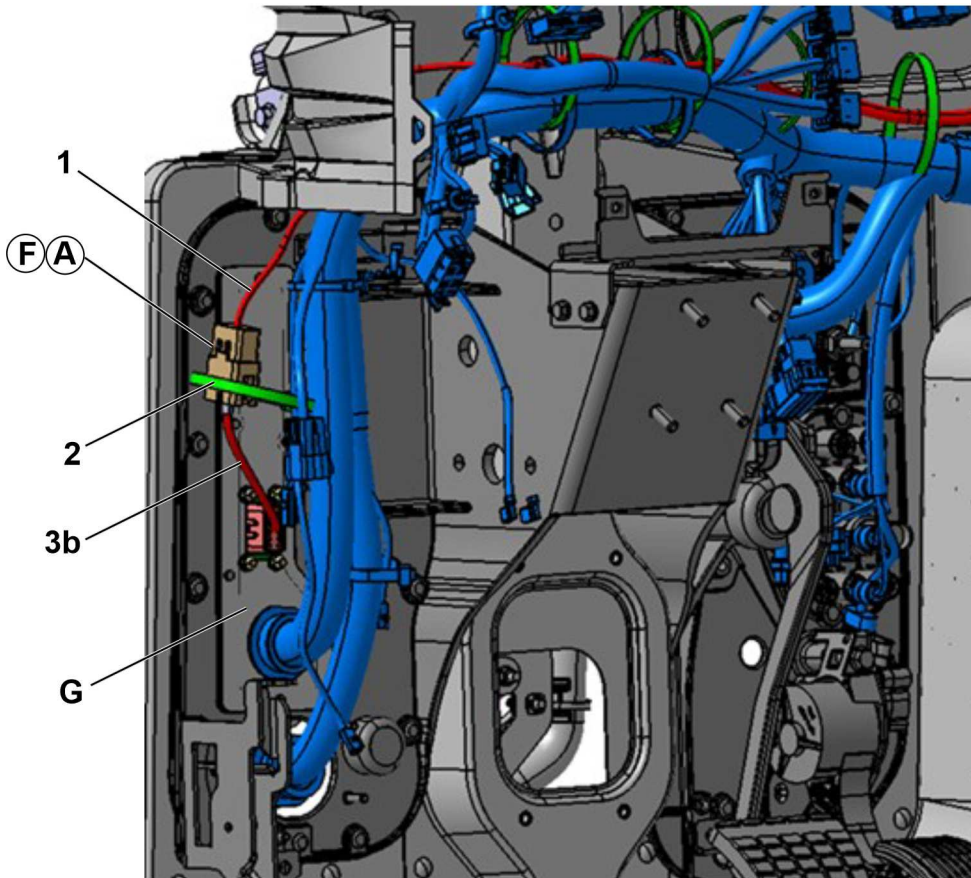

T3161290

A	The snow plow dashboard overlay harness (red) should follow and be cable tied to the main cab harness (blue)
F	Connect the EPDMP_A connector to the EPDMP_A pigtail jumper harness
G	Existing EPDM plate cover (82786099) has to be replaced with new EPDM plate cover (84755571)
3b	Wires (EPDM pigtail jumper - 23266504)
1	Wires (dashboard overlay - 23783544)
2	Cable tie (980464)

Auxiliary lamps switch harness on the dashboard sheet

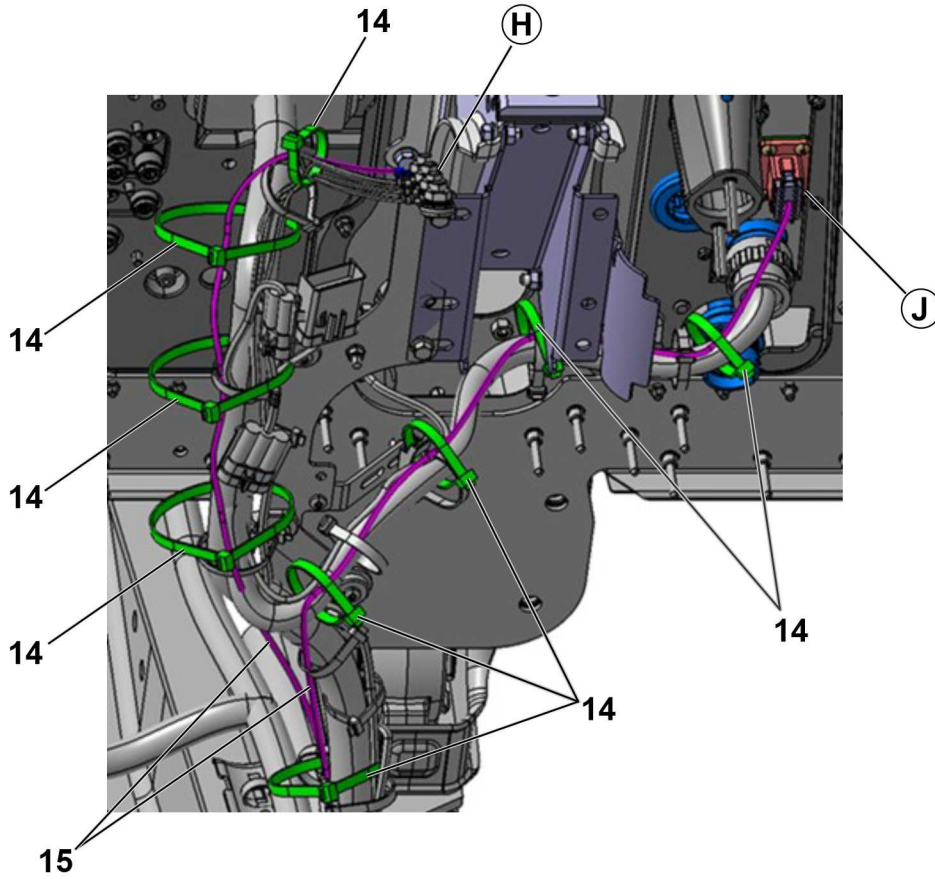

T3161289

H	The snow plow lamps chassis overlay harness (purple) should follow and cable tied to the front chassis harness (gray). The X209 ring terminal (labeled X209) on the snow plow lamps chassis overlay harness (purple) should be placed on the ground stud and torque tighten the nut to 100 in-lbs maximum.
J	The snow plow lamps chassis overlay harness (purple) should follow and cable tied to the front chassis harness (gray). Connect the EPDMP_B (labeled EPDMP) connector on the snow plow lamps chassis overlay harness (purple). The EPDMP_B connector is the pigtail jumper harness connector attached to the firewall.
14	Cable tie (980464)

Snow plow lamps chassis overlay harness

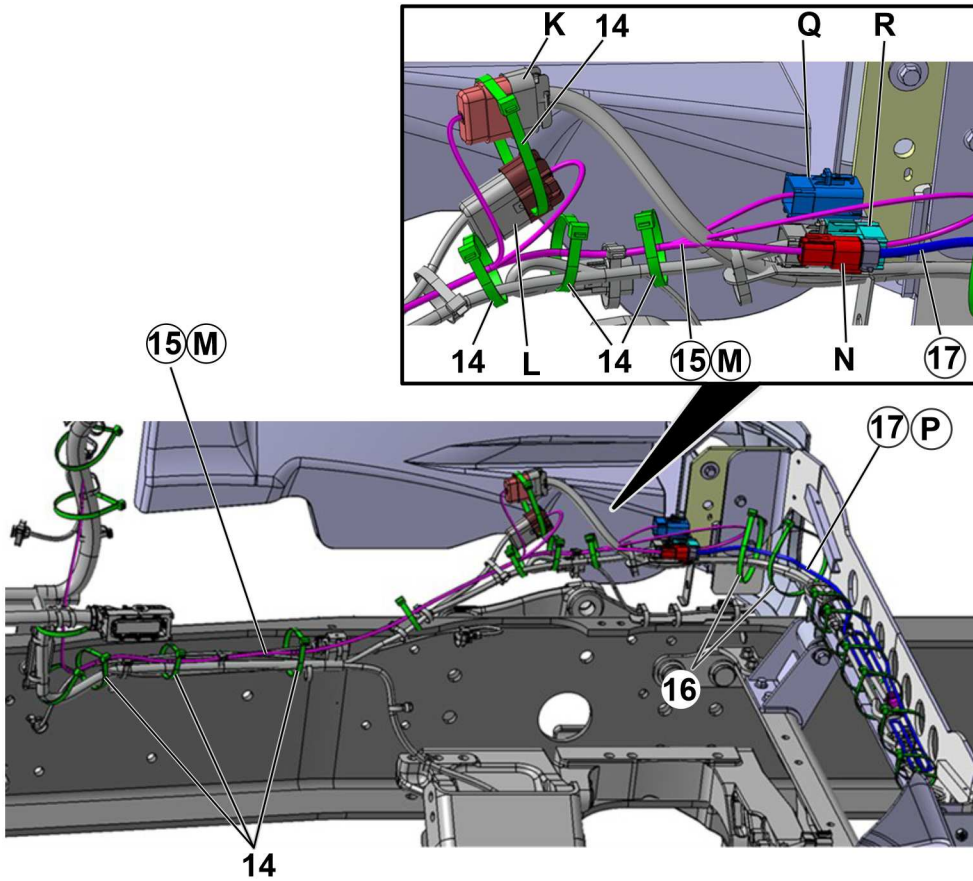

T3161291

K	Snow plow lamps connector (labeled : Plow lamps) connect to the snow plow harness connector.
L	The snow plow lamps connector (labeled: FC plow lamps) connects to the front chassis harness connector.
M	The snow plow lamps chassis overlay harness (purple) should follow and cable tied to the front chassis harness (gray).
N	Auxiliary lamp connector (labeled : AUX lamp) connect to the auxiliary lamp connector on the auxiliary lamp harness.
P	The auxiliary lamps chassis front harness (blue) should be connected to the snow plow lamps chassis overlay harness (purple) and cable tied to the front chassis harness (gray).
Q	Headlamp connector (labeled : Headlamp) connect to the headlamp harness connector.
R	Headlamp connector (labeled : FC headlamp) connect to the front chassis harness headlamp connector.
14	Cable tie (980464)
15	Wires (front chassis overlay - 23783546)
17	Wires (auxiliary lamp overlay - 23734646)

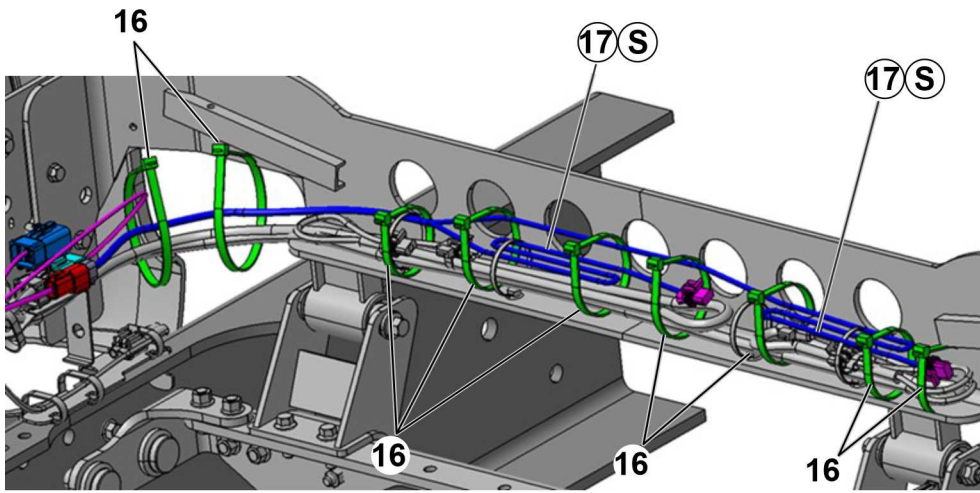

T3161292

S	The auxiliary lamps front harness (blue) should follow and cable tied to the snow plow hood harness. The excess harness should be bundled up and cable tied to the snow plow hood harness (gray).
16	Cable tie (980464)
17	Wires (auxiliary lamp overlay - 23734646)

Wiring connection matrix

Location of auxiliary lamps connectors

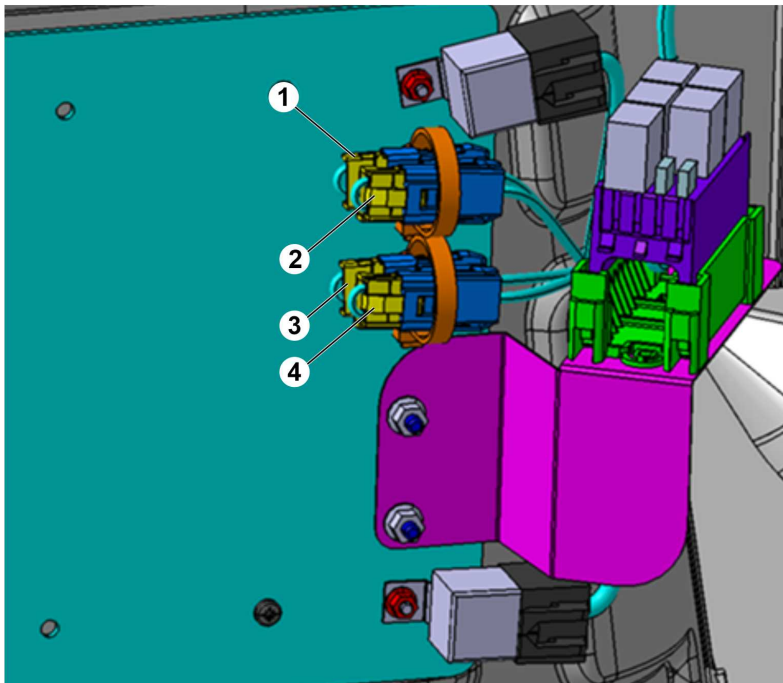

T3161340

- 1 Socket (Truck Lamps High Beam)
- 2 Socket (Truck Lamps Low Beam)

- 3 Socket (Plow Lamps High Beam)
- 4 Socket (Plow Lamps Low Beam)

The auxiliary lamps and headlamps sockets are mounted on the panel that is located behind the cup holder on the dog house cover. To access the panel, remove the cup holder.

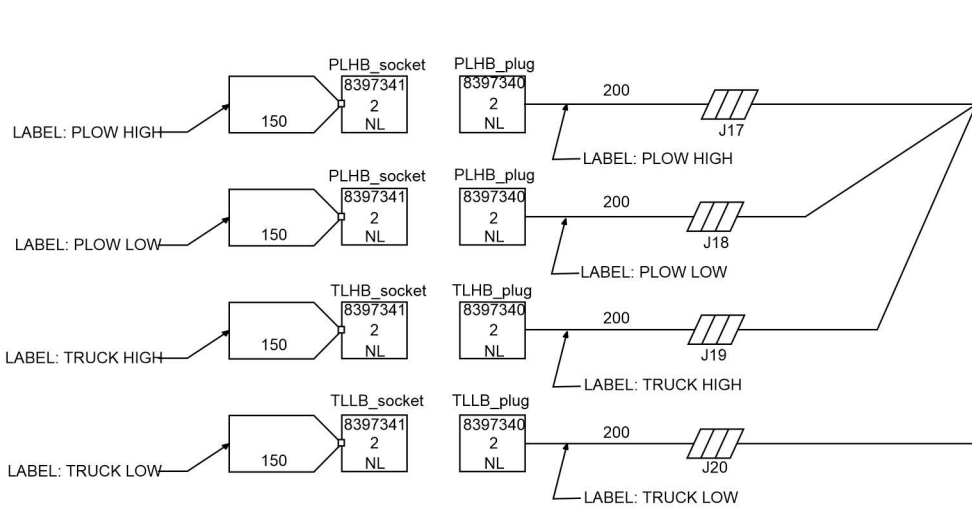

T3161341

PLHB	Plow Lamps High Beam
PLLB	Plow Lamps Low Beam

TLHB	Truck Lamps High Beam (headlamps)
TLLB	Truck Lamps Low Beam (headlamps)

Unplug the auxiliary lamps connectors to allow the headlamps to stay on in the application.

Note: Refer wiring diagram section of "Mack Conventional-Gen2-US17GHG" for the wiring schematics of "SNOW PLOW PREP W/ EXTRA AUX LIGHTS V2 (NJX-A9X)".

General

Data Link System

This section provides information on the design and function of the vehicle communications data links. These communication links are based on SAE J1587, J1708 and J1939 Recommended Practices and the ISO 14229 Standard. For more specific information about the ISO 14229 Standard, please refer to the ISO website (www.iso.org).

The data links are used to relay shared vehicle information between control modules and diagnostic, service and (in the case of on-board diagnostic (OBD) information) scan tools. The three data link types used are SAE J1939, SAE J1587/J1708 and ISO 14229.

SAE J1939

SAE J1939 is a communications link between stand-alone vehicle modules. This data link is commonly referred to as the “Control data link”.

It is used primarily to transmit control signals that are shared between other stand-alone modules. The information on the SAE J1939 control link is used for control functions. Fault messages or diagnostic information also transmits across this link. These control signals may be for, engine, transmission, brakes or a number of other vehicle control needs.

The J1939 operates at 250,000 bits per second (250K Baud Rate), which is approximately 26 times faster than the J1708/1587 data link. This higher speed allows the system to operate at a faster sampling rate and higher resolution, thus being more capable of providing better control of vehicle functions.

The J1939 data link consists of a pair of 18 gauge unshielded twisted wires. The designations of the networks are CAN_H and CAN_L. The designation of the individual wires are DL1H that is yellow and DL1L that is green. The nominal rate of twist required is 0.89 twists per 25.4 mm (1 inch) or 33 twists per meter (3.28 feet). This twist helps protect against electrical interference.

The J1939 data link is electrically terminated at each end with a load resistor, which is commonly referred to as a termination resistor. Each J1939 network has two termination resistors associated with it. Only two termination resistors are allowed within a network. The termination resistor can be located external as part of the wiring harness, or integrated internally in the ECM. Any ECM that does not contain the termination resistor is referred to as a Type I, and an ECM that contains the termination resistor is referred to as a TYPE II. The correct number of termination resistors can be easily checked by measuring the resistance across cavities C and D of the 9-pin diagnostic connector or across cavities 3 and 11 for the 16-pin diagnostic connector. The correct resistance is 50 – 70 ohms. The terminating resistors should each have a resistance of 110 – 130 ohms when tested individually.

Note: It is important to remember which control units the vehicle is equipped with and which fault codes are stored in each control unit.

Do not splice into a V-MAC, ABS/ATC or any other electronic control unit harness.

Note: Do not cut or tap into the J1939 green/yellow twisted wires or any other wire or harness used on this vehicle. Use the provided connectors, and only add approved J1939 components with validated software. Failure to comply may result in personal injury or equipment damage. Any cutting, splicing, alteration or modification to the wiring will Void the Mack Trucks Warranty on the Electrical System.

Mack follows SAE J1939-15 meaning it uses an unshielded, twisted pair and is theoretically limited to ten devices.

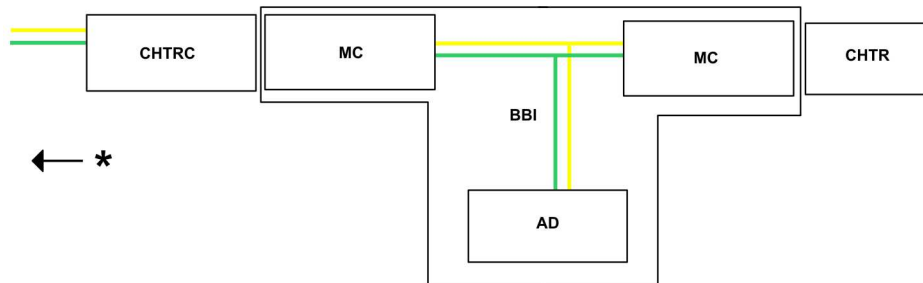

W3083536

Fig. 34 Adding a Node at the Terminating Resistor

* To Truck

The following parts can be used in the above “T” harness. Critical is that only two terminating resistor remain on the network (one is in the ECM). It may also be possible to have one terminating resistor in the aftermarket device if it is replacing the terminating resistor.

T Harness Part Numbers

T Harness					
Abbreviation	Connector	Part Number (New)		Part Number (Old)	
		MACK #	Delphi #	MACK #	Deutsch #
CHTRC	Cab Harness Terminating Resistor Connector	21430472	13510085	3187784	DTM04-2P
CHTR	Cab Harness Terminating Resistor 120 Ω	21430457	15429045	25171700	DTM06-2S-P006
	Connection to Cab harness	20500398	13510099	3187782	DTM06-2S
AD	Aftermarket Device	N/A	N/A	N/A	
MC	Mating Connector	N/A	N/A	N/A	
BBI	Body Builder Installed	N/A	N/A	N/A	

Vehicle Accessory Connector (Mack Conventional)

Note: Vehicle accessory connectors are applicable for vehicles built on or after Monday, September 07, 2020.

The purpose of vehicle accessory connector (TMC RP1226) is to connect the vendor device to the vehicle.

This connector provides an intuitive and quality assured interface between the vehicle and vendor device.

Location of the connectors

Two accessory connectors are located under the instrument panel. The connectors are used to connect the aftermarket Fleet Management devices. Only one vendor device is allowed to connect per connector.

Note: The vendor device must not have an internal termination resistor.

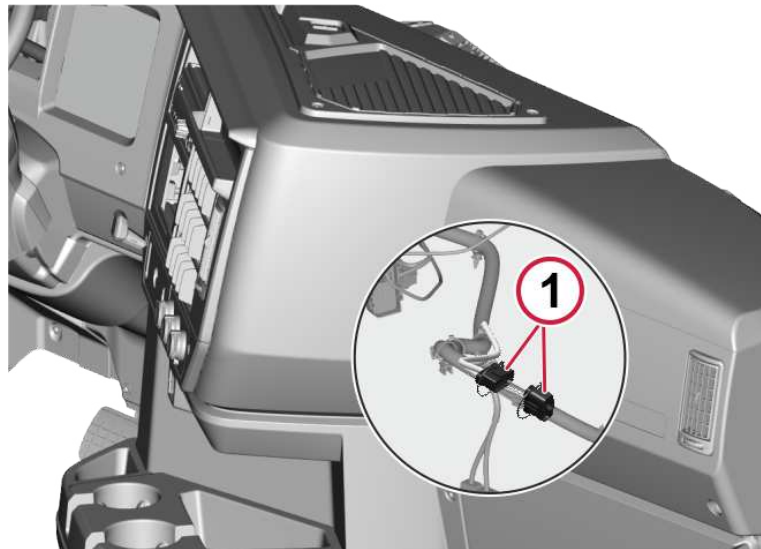

T3159519

TMC RP1226 Connector

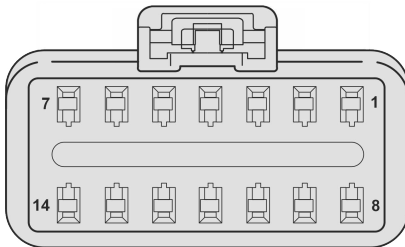

T3159520

Pin numbers	Description
1	+12 V After battery switch (10 A shared)
2	CAN-5
3	—
4	—
5	—
6	J1708A
7	+12 V After ignition (10 A shared)
8	Ground

9	CAN-5 Low
10	—
11	—
12	—
13	J1708B
14	+12 V Battery (10 A shared)

Mating Connector

The following connector and terminals must be used, if the vendor component connector not suitable to connect to the TMC RP1226 connector.

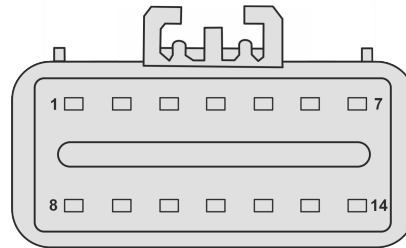

T3159741

Description	Part number
Mating connector	20734995
Terminals	21712912

ISO 14229

Note: ISO 14229 only applies to vehicles with MACK engines.

ISO 14229 is the Powertrain control link. The ISO is used for programming between the ECM, ACM and TCM. It is used primarily to transmit control signals that are shared between other stand-alone modules. The information on the ISO 14229 control link is used for control functions. Fault messages or diagnostic information also transmits across this link. These control signals may be for engine, transmission and aftertreatment ECUs.

The ISO 14229 operates at 500,000 bits per second (500K Baud Rate). This higher speed allows the system to operate at a faster sampling rate and higher resolution, thus being more capable of improving programming and diagnostic time..

The ISO 14229 data link consists of a pair of 18 gauge unshielded twisted wires. The designations of the networks are CAN_H and CAN_L . The designations of the individual wires are DL2H and DL2L that are both white with orange stripes. The nominal rate of twist required is 40 twists per meter (3.28 feet). This twist helps protect against electrical interference.

The ISO 14229 data link is electrically terminated at each end with a load resistor, which is commonly referred to as a termination resistor. Each ISO 14229 network has two termination resistors associated with it. Only two termination resistors are allowed within a network. The termination resistor can be located external as part of the wiring harness, or integrated internally in the ECU/ECM. Any ECU/ECM that does not contain the termination resistor is referred to as a Type I, and an ECU/ECM that contains the termination resistor is referred to as a TYPE II. The correct number of termination resistors can be easily checked by measuring the resistance across cavities 3 and 11 for the 16-pin diagnostic connector. The correct resistance is 50 – 70 ohms. The terminating resistors should each have a resistance of 110 – 130 ohms when tested individually.

Note: It is important to remember which control units the vehicle is equipped with and which fault codes are stored in each control unit.

SAE J1708/1587

Note: MACK engines and *mDRIVE* transmissions do not include the J1587/J1708 data link.

SAE J1708/1587 is a communications link between stand-alone vehicle modules. This data link is commonly referred to as the "Information data link". It is used primarily to transmit shared information between these stand-alone modules. Fault messages or diagnostic information also transmits across this link. The J1708/1587 exchanges information with a data bus speed of 9600 bits per second (9.6K Baud Rate). The J1708 defines parameters that relate primarily to hardware and basic software compatibility. The J1587 defines the actual data to be transmitted by particular modules. The J1587/1708 data link consists of a pair of 18 gauge twisted wires. The nominal rate of twist required is 1 twist per 25.4 mm (1 inch) or 40 twists per meter (3.28 feet). This twist helps protect against electrical interference. A fault in this data link can affect the transfer of information, and can make it difficult to communicate with the source in order to carry out tests using VCADS (found in the Premium Tech Tool or PTT). An indication that there is a problem with SAE J1708/1587 can be that faults from a certain control unit cannot be corrected, erased or reset.

Data Link Faults



W3005017

Whenever a data link fault is present, refer to Guided Diagnostics found in the manufacturer's scan tool (Premium Tech Tool or PTT) for diagnostic information.

Note: The ISO 14229 does not have FMIs. Instead this data link has failure type bytes (FTBs).

- The type of FMI/FTB that an individual electronic control unit (ECU) can monitor depends on the software in the ECU. All FMIs/FTBs cannot be recognized by all ECUs.
- The ECU reporting the diagnostic trouble code (DTC) may not be the ECU that is involved at the site of the specific failure. For example, The engine control module (ECM) may report a data link fault that is actually at the vehicle electronic control unit (VECU). The VECU would not be able to report if the data link is broken between the VECU and data link backbone.

Data link Topology

Mack Conventional Trucks: US2017 and later Emissions Engine

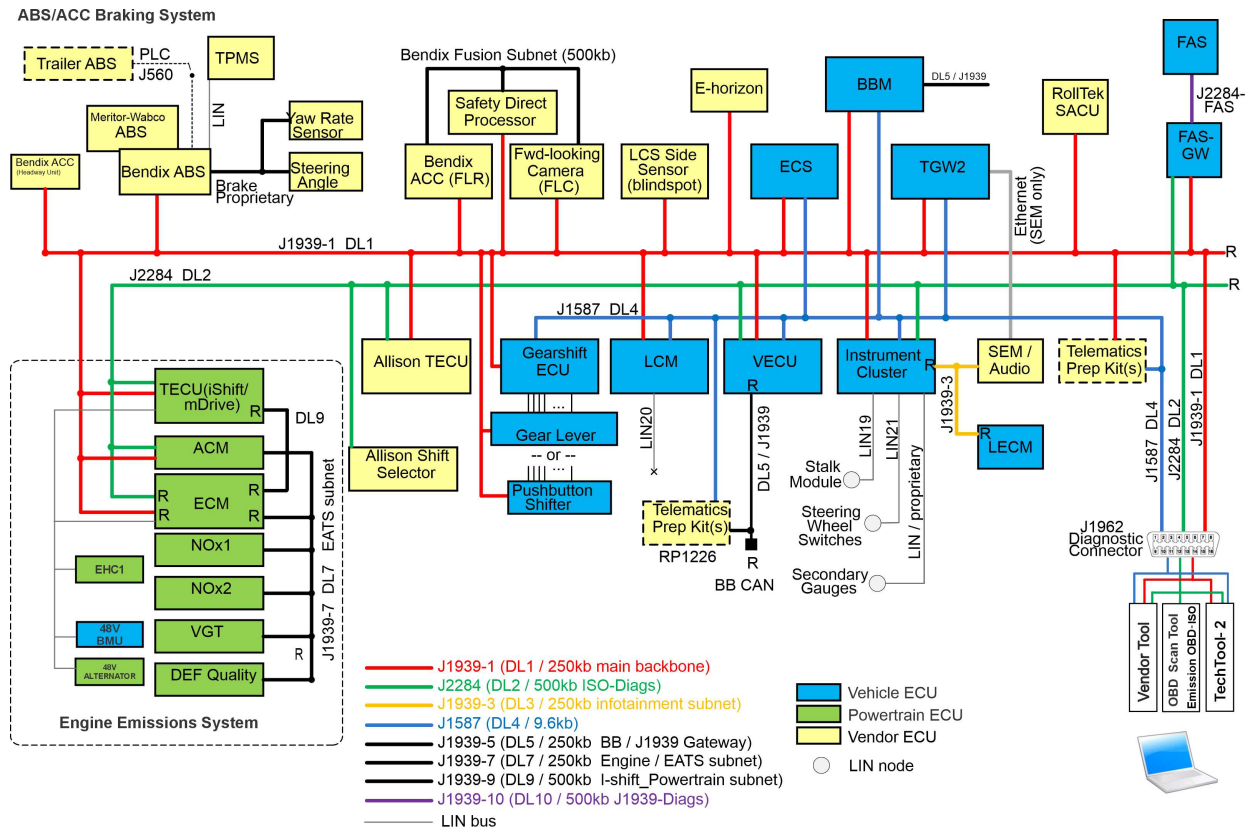

T3206003

Note: Only for CARB24 emission regulation, the LIN connection to EHC, BMU and 48v alternator from TECU and ECM are applicable.

Acronym	Description
ABS	Anti-lock braking system
ACC	Adaptive Cruise Control
ACM	Aftertreatment Control Module
BBM	Body Builder Module
BMU	Battery Management Unit
CAN	Control Area Network
DEF	Diesel Exhaust Fluid
ECM	Engine Control Module
ECS	Electronically Controlled Suspension
EHC	Electric Heater Control
FAS	Front Active Steering
FAS-GW	Front Active Steering Gateway
FLC	Forward Looking Camera
GSECU	Gear Selector ECU

Acronym	Description
LCS	Lane Change System
LCM	Light Control Module
LECM	Living Environment Control Unit
LIN	Local Interconnect Module
NOx	Nitrogen Oxide
SACU	Seat Adjustment Control Unit
SEM	Services and Entertainment Module
TECU	Transmission Electronic Control Unit
TGW2	Telematics Gateway2
TPMS	Tire Pressure Monitoring System
VGT	Variable Geometry Turbocharger

Mack Conventional Trucks: US2017 and later Emissions Cummins 9 liter Engine (plus OBD2016 and later)

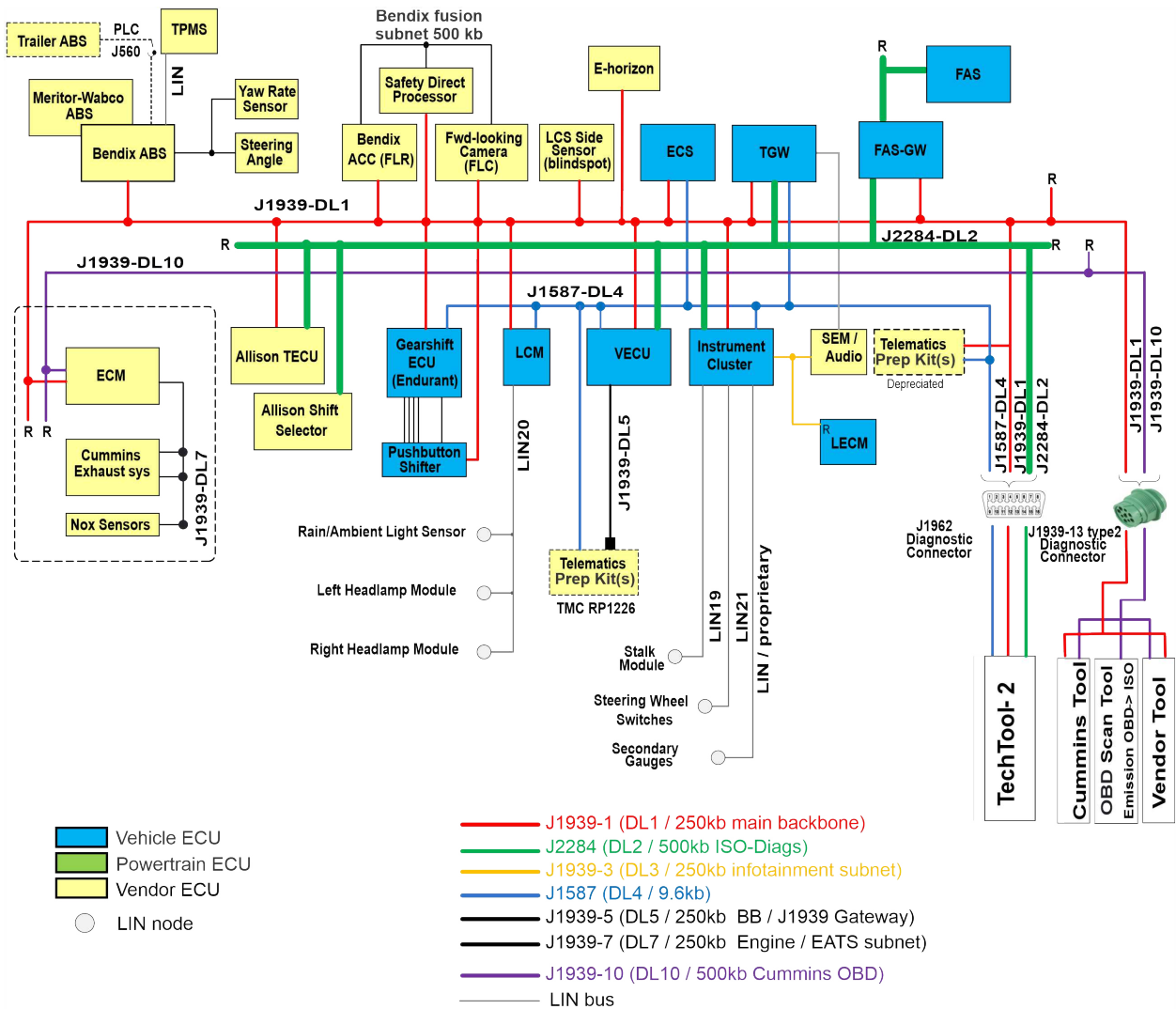

T3199295

Acronym	Description
ABS	Anti-lock Braking System
ACC	Adaptive Cruise Control
BBM	Body Builder Module
DL	Data Link
ECM	Engine Control Module
ECS	Electronically Controlled Suspension
FAS	Front Axle Steering
FAS-GW	Front Axle Steering- Gateway
FLC	Forward Looking Camera
FLR	Forward Looking Radar
LCM	Light Control Module
LCS	Lane Change System
LECM	Living Environment Control Module
NOx	Nitrogen Oxide
OBD	On-board Diagnostics
SEM	Service and Entertain Module
TCM	Transmission Control Module
TECU	Transmission Electronic Control Unit
TPMS	Tire Pressure Monitor System
VECU	Vehicle Electronic Control Unit

Note: Not all listed ECUs are available on every vehicle.

Mack Conventional Trucks: US2017 and later Emissions Cummins 12 liter Engine (plus OBD2016 and later)

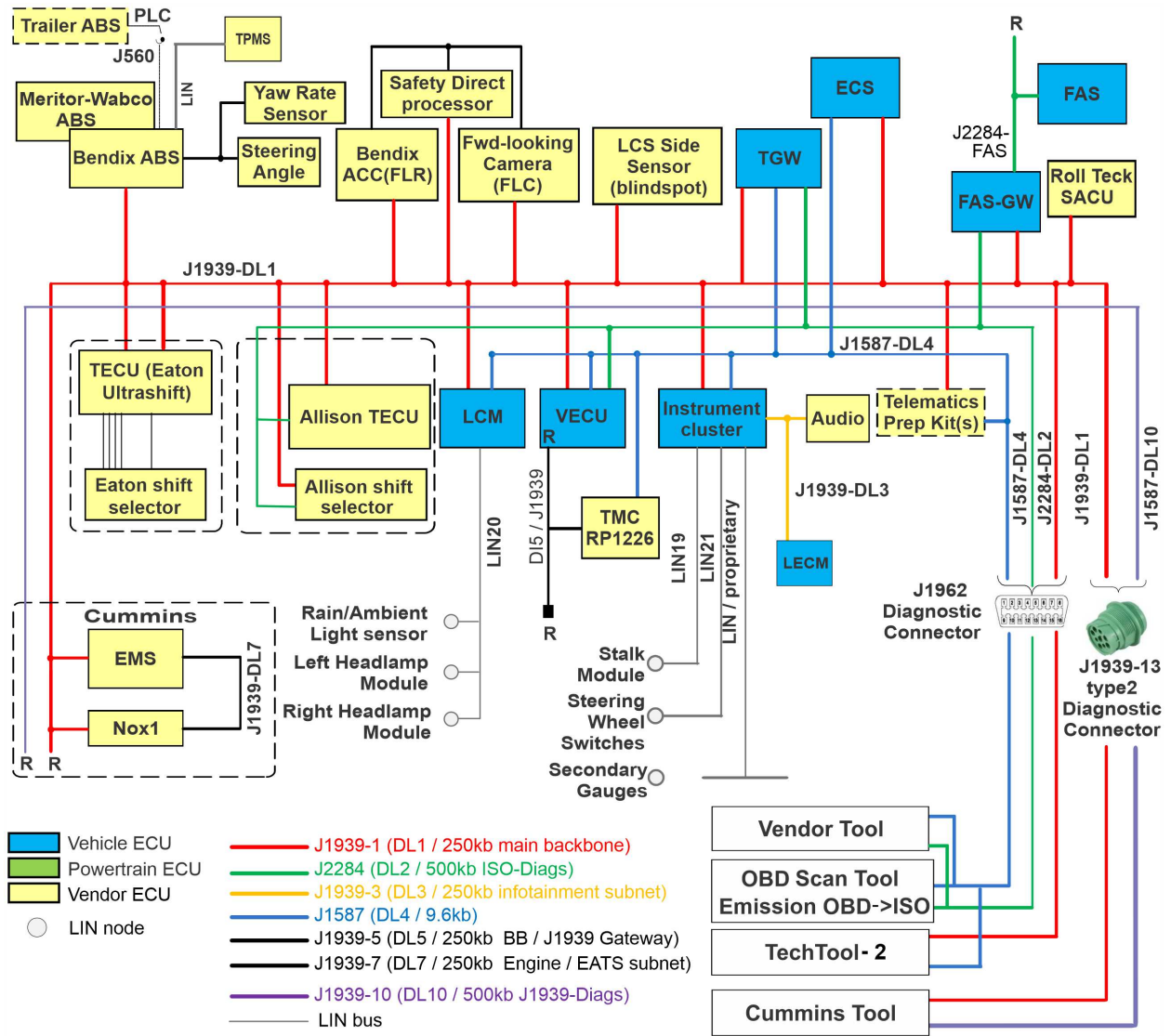

T3173623

Acronym	Description
ABS	Anti-lock Braking System
ACC	Adaptive Cruise Control
ACM	Aftertreatment Control Module
BBM	Body Builder Module
DEF	Diesel Exhaust Fluid
DL	Data Link
ECC/MCC	Electronic Climate Control/ Manual Climate Control
ECM	Engine Control Module
ECS	Electronically Controlled Suspension
FAS	Front Axle Steering
FAS-GW	Front Axle Steering- Gateway

Acronym	Description
FLC	Forward Looking Camera
FLR	Forward Looking Radar
GSECU	Gear Selector Electronic Control Unit
LCM	Light Control Module
LCS	Lane Change System
LECM	Living Environment Control Module
NOx	Nitrogen Oxide
OBD	On-board Diagnostics
SACU	Side Airbag Control Unit
SCU	Satellite Control Unit (Qualcomm)
SEM	Service and Entertain Module
SDP	Safety Direct Process
SRS	Supplemental Restraint System
TCM	Transmission Control Module
TECU	Transmission Electronic Control Unit
TPM	Tire Pressure Monitor
VECU	Vehicle Electronic Control Unit
VGT	Variable Geometry Turbocharger

Note: Not all listed ECUs are available on every vehicle.

Mack Cab over Trucks: US2017 and later Emissions Engine (plus OBD2018 and later)

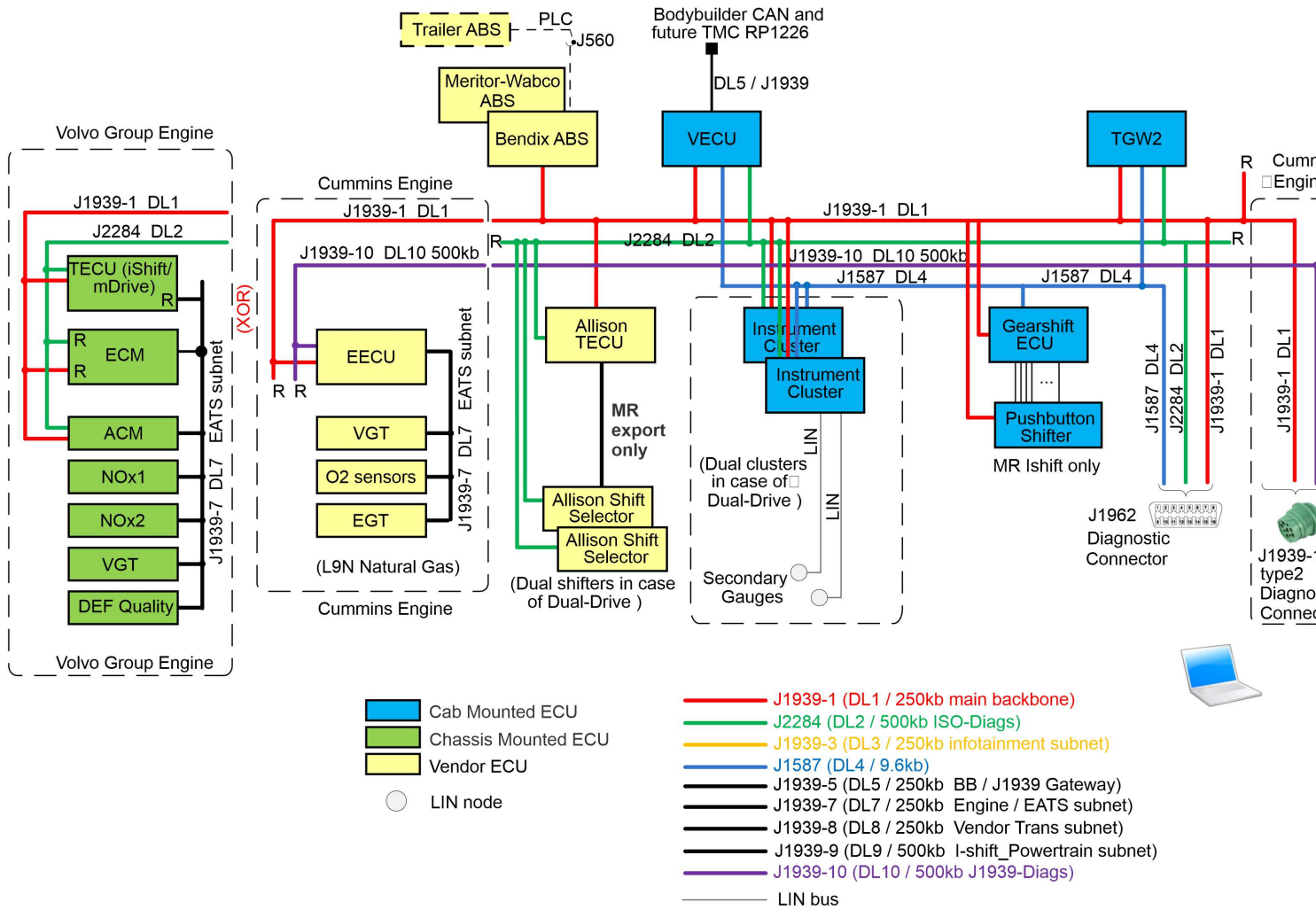

Note: VGT is not applicable to 13 L TC (turbocompound) Engine

Acronym	Description
ABS	Anti-lock braking system
ACM	Aftertreatment Control Module
DEF	Diesel Exhaust Fluid
ECM	Engine Control Module
EECU	Engine Electronic Control Unit
EGT	Exhaust Gas Temperature
GSECU	Gear Selector ECU
LIN	Local Interconnect Module
NOx	Nitrogen Oxide
TECU	Transmission Electronic Control Unit

Acronym	Description
TGW2	Telematics Gateway2
VGT	Variable Geometry Turbocharger

Termination Resistor

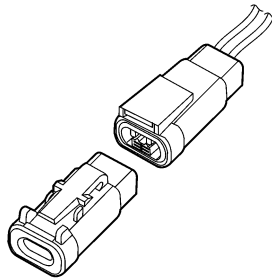

W3005518

Termination Resistor, 2-pin

Termination Resistor – J1939

Termination resistors are wired to each end of the SAE J1939 data link to prevent signal reflections. They must remain connected for the data link to function properly. The resistance value of each termination resistor is 110 – 130 Ω . When properly installed in the data link, their combined resistance is 50 – 70 Ω since they are connected in parallel.

The termination resistor at one end of the SAE J1939 data link is located in the fuse and relay centre (FRC) near the vehicle electronic control unit (VECU) and the other near the engine control module (ECM). On vehicles equipped with MACK engines, the termination resistor at the engine end is located inside the ECM. On vehicles equipped with Cummins engine, the termination resistor is located in the harness area just outside of the ECM.

A SAE J1939 data link connection is located at the transmission area in the chassis harness. On vehicles equipped with an electronically controlled transmission (Allison/Autoshift II/Meritor Freedom Line), the connection to the transmission is located at the chassis harness. On vehicles equipped with a manual non-electronically controlled transmission - the connector stub will have an unterminated blanking plug installed.

Only two termination resistors are used in each data link. Never install more than two terminator resistors in one data link. If more than two resistors exist in the SAE J1939 data link circuit, incorrect or absent signals may occur. You can easily check to see if you have two resistors by measuring the resistance between pin C and D for the 9-pin diagnostic connector, or pin 3 and 11 for the 16-pin diagnostic connector, with the ignition key in OFF position. The correct resistance is 50 – 70 Ω . The termination resistors should each have a resistance of 110–130 Ω when tested individually.

Termination Resistor – ISO 14229

Termination resistors are also wired for the ISO 14229 data link. One resistor is located in the engine control module (ECM). The other is a two-pin resistor located in the dashboard close to the diagnostic connector. The diagnostic connector is located on the driver's side lower instrument panel. Termination resistors must remain connected for the data link to function properly. The resistance value of each termination resistor is 110 – 130 Ω . When properly installed in the data link, their combined resistance is 50 – 70 Ω since they are connected in parallel

The termination resistor at one end of the ISO 14229 data link is located in the fuse and relay centre (FRC) near the vehicle electronic control unit (VECU) and the other near the engine control module (ECM). On vehicles equipped with MACK engines, the termination resistor at the engine end is located inside the ECM.

A ISO 14229 data link connection is located at the transmission area in the chassis harness. On vehicles equipped with an electronically controlled transmission (Allison/Autoshift II/Meritor Freedom Line), the connection to the transmission is located at the chassis harness. On vehicles equipped with a manual non-electronically controlled transmission - the connector stub will have an unterminated blanking plug installed.

Only two termination resistors are used in each data link. Never install more than two terminator resistors in one data link. If more than two resistors exist in the ISO 14229 data link circuit, incorrect or absent signals may occur. You can easily check to see if you have two resistors by measuring the resistance between pin 3 and 11 for the 16-pin diagnostic connector, with the ignition key in OFF position. The correct resistance is 50 – 70 Ω . The termination resistors should each have a resistance of 110 – 130 Ω when tested individually.

Notes

Another more convenient way to connect to J1939 (or J1587) is through the diagnostic connector.

9-pin Diagnostic Connector

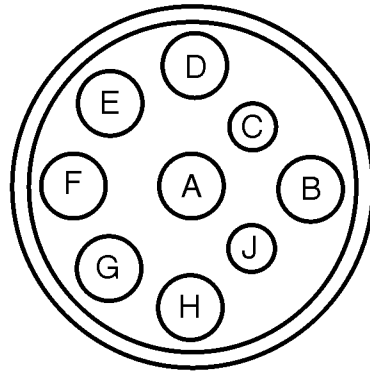

W9000628

Fig. 35 9-pin Diagnostic Connector

Note: Export Engines Only

9-pin Diagnostic Connector

9-pin Diagnostic Connector	
Pin	Definition
A	Ground
B	Battery
C	CAN H (J1939 H-Yellow)
D	CAN L (J1939 L-Green)
E	Not used (Shield)
F	J1587 +
G	J1587 -
H	Not Used
J	Ignition + (Key Switch)

16-pin Diagnostic Connector

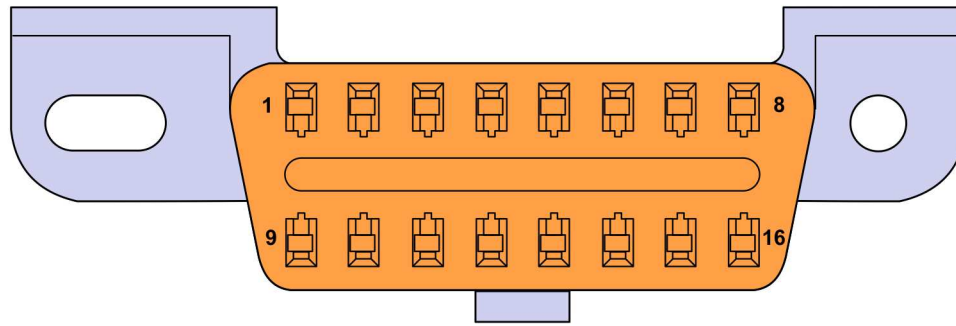

W3085011

Fig. 36 16-pin Diagnostic Connector (OBD 13)

16-pin Diagnostic Connector (OBD 13) Pin Allocation

16-pin Diagnostic Connector (OBD 13 SAE J1962-Type A Connector)	
Pin	Definition
1	OEM discretionary (assigned as: Key switch – ignition signal for AM tool)
2	(Not Used)
3	OEM discretionary (assigned as: SAE J1939-15_CAN_H)
4	Chassis ground
5	Chassis ground
6	CAN_H line of ISO
7	(Not Used)
8	(Not Used)
9	(Not Used)
10	(Not Used)
11	OEM discretionary (assigned as: SAE J1939-15_CAN_L)
12	OEM discretionary (assigned as: SAE J1587 positive)
13	OEM discretionary (assigned as: SAE J1587 negative)
14	CAN_L line of ISO
15	(Not Used)
16	Battery positive voltage

Supported DL1 SAE J1939 Serial Messages

Note: Mack does not recommend broadcasting on the databus. However, it is known that there are devices on the market which affect an engine speed control.

Mack broadcasts the following with message and signal definition per SAE J1939-71. Exceptions noted. Dates are build dates rather than model year. Most changes correspond with emissions regulation.

SAE J1939 Messages

SAE J1939 Messages							
PGN	Message Name	Source Address	SPN	Signal Name	Usage	Notes	
65198	Air Supply Pressure	23	1087	Service Brake Circuit 1 Air Pressure	Conventional Since 2007		
			1088	Service Brake Circuit 2 Air Pressure			
			46	Pneumatic Supply Pressure			
65269	Ambient Conditions	0, 17, 23	171	Ambient Air Temperature	SA 23 Since 2007 & SA 0.17 since 2010	23 – Sensor Source	
			0	108	Barometric Pressure	Since 2007	
				172	Engine Air Intake Temperature		
64891	Aftertreatment 1 Service	0	3719	Aftertreatment Diesel Particulate Filter 1 Soot Load Percent	Since 2007		
			3720	Aftertreatment Diesel Particulate Filter 1 Ash-Load Percent			
65110	Aftertreatment 1 SCR Reagent Tank 1 Information	0	1761	Aftertreatment 1 SCR Catalyst Tank Level	Since 2010		
			3517	Aftertreatment 1 SCR Catalyst tank Level 2			
			5245	Aftertreatment 1 DEF Tank Low-Level Indicator			
			5246	Aftertreatment SCR Operator Inducement Severity			
64946	Aftertreatment 1 Intermediate Gas	0	3251	Aftertreatment 1 Diesel Particulate Filter Differential Pressure	Since 2007		
64947	Aftertreatment 1 Outlet Gas 2	0	3246	Aftertreatment 1 Diesel Particulate Filter Outlet Gas Temperature	Since 2007		

SAE J1939 Messages							
PGN	Message Name	Source Address	SPN	Signal Name	Usage	Notes	
64948	Aftertreatment 1 intake Gas 2	0	3242	Aftertreatment 1 Diesel Particulate Filter Intake Gas Temperature	Since 2007		
65265	Cruise Control/Vehicle Speed	17	84	Wheel-Based Vehicle Speed	All		
			86	Cruise Control Set Speed			
			595	Cruise Control Active			
			596	Cruise Control Enable Switch			
			597	Brake Switch			
			598	Clutch Switch			
			599	Cruise Control Set Switch			
			600	Cruise Control Coast (Decelerate) Switch			
			601	Cruise Control Resume Switch			
			602	Cruise Control Accelerate Switch			
			976	PTO Governor State			Reflects engine speed control state not PTO input or output state.
			527	Cruise Control States			
70	Parking Brake Switch						
57344	Cab Message 1	23	3695	Diesel Particulate Filter Regeneration Inhibit Switch	Since 2007		
			3696	Diesel Particulate Filter Regeneration Force Switch			
			1856	Seat Belt Switch			Since 2010
65276	Dashboard Display	23	96	Fuel Level 1	Since 2007		
65226	DM1	0			Since 2007		
64952	DM26	0			Since 2010		

SAE J1939 Messages

PGN	Message Name	Source Address	SPN	Signal Name	Usage	Notes
64892	Diesel Particulate Filter Control 1	0	3697	Diesel Particulate Filter Lamp Command	Since 2007	
			3698	Exhaust System High Temperature Lamp Command		
			3699	Diesel Particulate Filter Passive Regeneration Status		
			3700	Diesel Particulate Filter Active Regeneration Status		
			3701	Diesel Particulate Filter Status		
			3702	Diesel Particulate Filter Active Regeneration Inhibited Status		
			3703	Diesel Particulate Filter Active Regeneration Inhibited Due to Inhibit Switch		
			3706	Diesel Particulate Filter Active Regeneration Inhibited Due to PTO Active		
			3707	Diesel Particulate Filter Active Regeneration Inhibited Due to Accelerator Pedal Off Idle		
			3709	Diesel Particulate Filter Active Regeneration Inhibited Due to Vehicle Speed Above Allowed Speed		
			3710	Diesel Particulate Filter Active Regeneration Inhibited Due to Parking Brake Not Set		
			3711	Diesel Particulate Filter Active Regeneration Inhibited Due to Low Exhaust Gas Temperature		
3712	Diesel Particulate Filter Active Regeneration Inhibited Due to System Fault Active					
64892 (cont.)	Diesel Particulate Filter Control 1	0	3714	Diesel Particulate Filter Active Regeneration	Since 2007	

SAE J1939 Messages						
PGN	Message Name	Source Address	SPN	Signal Name	Usage	Notes
				Inhibited Due to Temporary System Lockout		
			3715	Diesel Particulate Filter Active Regeneration Inhibited Due to Permanent System Lockout		
			3716	Diesel Particulate Filter Active Regeneration Inhibited Due to Engine Not Warmed Up		
			3698	Exhaust System High Temperature Lamp Command		
61441	Electronic Brake Controller 1	11	561	ASR Engine Control Active	Per ABS type	
			562	ASR Brake Control Active	Per ABS type	
			563	Anti-Lock Braking (ABS) Active		
			1121	EBS Brake Switch	Not Used	
			521	Brake Pedal Position	Not Used	
			575	ABS Off-road Switch	Per ABS type	
			576	ASR Off-road Switch	Per ABS type	
			577	ASR "Hill Holder" Switch	With I-shift/ mDrive	
			1238	Traction Control Override Switch	Per ABS type	
			1243	ABS Fully Operational		
			1438	ABS/EBS Amber Warning Signal (Powered Vehicle)		
			1793	ATC/ASR Information Signal	Per ABS type	
			1481	Source Address of Controlling Device for Brake Control	Per ABS type	
			1836	Trailer ABS Status	Per ABS type	
			1792	Tractor-Mounted Trailer ABS Warning Signal	Per ABS type	

SAE J1939 Messages						
PGN	Message Name	Source Address	SPN	Signal Name	Usage	Notes
65215	Wheel Speed Information	11	904	Front Axle Speed	All	
			905	Relative Speed; Front Axle, Left Wheel		
			906	Relative Speed; Front Axle, Right Wheel		
			907	Relative Speed; Rear Axle #1, Left Wheel		
			908	Relative Speed; Rear Axle #1, Right Wheel		
			909	Relative Speed; Rear Axle #2, Left Wheel		
			910	Relative Speed; Rear Axle #2, Right Wheel		
64964	Electronic Brake Controller 5	11	2912	Hill holder mode	With Ishift/mDrive	
61444	Electronic Engine Controller 1	0	899	Engine Torque Mode	All	20 ms fixed rate
			512	Driver's Demand Engine - Percent Torque		
			513	Actual Engine - Percent Torque		
			190	Engine Speed		
			1483	Source Address of Controlling Device for Engine Control		
			1675	Engine Starter Mode		
61443	Electronic Engine Controller 2	0	558		All	From SA 17 with Cummins
			91	Accelerator Pedal Position 1		
			92	Engine Percent Load At Current Speed		
65247	Electronic Engine Controller 3	0	514	Nominal Friction - Percent Torque	All	
64981	Electronic Engine Controller 5		2791	Engine Exhaust Gas Recirculation 1 (EGR1) Valve Control	Since 2007	
			2795	Engine Variable Geometry Turbocharger (VGT) 1 Actuator Position	All	
65263	Engine Fluid Level/Pressure 1	0	94	Engine Fuel Delivery Pressure	All	
			98	Engine Oil Level		

SAE J1939 Messages						
PGN	Message Name	Source Address	SPN	Signal Name	Usage	Notes
			100	Engine Oil Pressure		
			101	Engine Crankcase Pressure		
			111	Engine Coolant Level		
65251	Engine Configuration 1	0			30 bytes	
61440	Electronic Retarder Controller 1	0, 15	900	Retarder Torque Mode	SA 15 before 2007	
			520	Actual Retarder - Percent Torque		
65262	Engine Temperature 1		110	Engine Coolant Temperature	All	
			174	Engine Fuel Temperature 1		
			175	Engine Oil Temperature 1		
61442	Electronic Transmission Controller 1	3	161	Transmission Input Shaft Speed	Automated transmissions	
			560	Transmission Driveline Engaged		
			573	Transmission Torque Converter Lockup Engaged		
			574	Transmission Shift In Process		
			4816	Transmission Torque Converter Lockup Transition in Process		
			191	Transmission Output Shaft Speed		SA 17 with Cummins
			522	Percent Clutch Slip		
			606	Engine Momentary Overspeed Enable		
			607	Progressive Shift Disable		
			5015	Momentary Engine Maximum Power Enable		
61445	Electronic Transmission Controller 2	3	524	Transmission Selected Gear	Automated transmissions	
			523	Transmission Current Gear		
			526	Transmission Actual Gear Ratio		

SAE J1939 Messages						
PGN	Message Name	Source Address	SPN	Signal Name	Usage	Notes
65134	High-Resolution Wheel Speed	11	1592	Front Axle, Left Wheel Speed	Since 2007	
			1593	Front axle, right wheel speed		
			1594	Rear axle, left wheel speed		
			1595	Rear axle, right wheel speed		
65270	Intake/Exhaust Conditions 1	0	173	Engine Exhaust Gas Temperature	Since 2007 SA 23 from 2004-2007	
			102	Engine Intake Manifold #1 Pressure	Since 2007	
			105	Engine Intake Manifold 1 Temperature		
			106	Engine Air Intake Pressure		
			107	Engine Air Filter 1 Differential Pressure		
65266	Fuel Economy (Liquid)	0	183	Engine Fuel Rate	Since 2007	
			184	Engine Instantaneous Fuel Economy		
			185	Engine Average Fuel Economy		
65254	Time/Date	23	959	Seconds	All	
			960	Minutes		UTC/GMT
			961	Hours		UTC/GMT
			962	Day		
			963	Month		
			964	Year		
			1601	Local minute offset		Display clock
			1602	Local hour offset		Display clock
65272	Transmission Fluids 1	3	177	Transmission Oil Temperature	Automated Transmissions	
0	Torque/Speed Control 1	3,11,17, 42, 230	695	Engine Override Control Mode	By options – engine brake,	
			898	Engine Requested Speed/Speed Limit		

SAE J1939 Messages						
PGN	Message Name	Source Address	SPN	Signal Name	Usage	Notes
			518	Engine Requested Torque/Torque Limit	transmission, etc.	
61449	Vehicle Dynamic Stability Control 2	11	1807	Steering Wheel Angle	Trucks with stability control	
			1808	Yaw Rate		
			1809	Lateral Acceleration		
			1810	Longitudinal Acceleration		
			1811	Steering Wheel Turn Counter		
			1812	Steering Wheel Angle Sensor Type		
65103	Vehicle Dynamic Stability Control 1	11	1813	VDC Information Signal	Trucks with stability control	
			1814	VDC Fully Operational		
			1815	VDC brake light request		
			1816	ROP Engine Control active		
			1817	YC Engine Control active		
			1818	ROP Brake Control active		
			1819	YC Brake Control active		
65217	High-Resolution Vehicle Distance	23	917	High-Resolution Total Vehicle Distance	All	
			918	High-Resolution Trip Distance		
65271	Vehicle Electrical Power 1	0	158	Key switch Battery Potential	Since 2007	
65260	Vehicle Identification	0	237	Vehicle Identification Number	Since 2010	
65135	Adaptive Cruise Control	42	1586	Speed of forward vehicle	By option	
			1587	Distance to forward vehicle		
			1588	Adaptive Cruise Control Set Speed		
			1589	Adaptive cruise control set distance mode		
			1590	Adaptive Cruise Control Mode		
			1796	ACC Distance Alert Signal		
			1797	ACC System Shutoff Warning		

SAE J1939 Messages						
PGN	Message Name	Source Address	SPN	Signal Name	Usage	Notes
			1798	ACC Target Detected		
			5022	Forward Collision Warning		
65264	Power take-off Information	17	980	Engine PTO Governor Enable Switch	Mack	
			984	Engine PTO Governor Set Switch		
256	Transmission Control 1	11	681	Transmission Gear Shift Inhibit Request	By ABS type with Automatic Transmission	
1024	External Brake Request	3	2920	External Acceleration Demand	<i>mDRIVE</i>	
			2914	XBR EBI Mode		
			2915	XBR Priority		
			2916	XBR Control Mode		
			3189	XBR Message Counter		
			3188	XBR Message Checksum		

Notes

Multiplexing Body Builder DL5 J1939 CAN

The multiplexing system BB J1939 CAN is used to provide control and communication between all major functional areas on a vehicle (engine, electrical, transmission, etc). The system offers simplified communication between the body builder module and other related electrical systems. Multiple signals are sent over a single pair of twisted wires, as opposed to individual wires for each function. The J1939 data link is used to send these signals.

The benefit of this arrangement is fewer wires, sensors and connections are required for communication purposes between systems. Also, there is greater signal consistency and reliability.

Multiplexing Parameters

SAE	CAN Network	Source of Message	Receiver of Message	Update Rate	PGN Signal Names (SPN)
ACC1 (65135)	J1939-X	VECU (as ACB)	Ext CAN	100 ms	Forward vehicle speed Forward vehicle distance ACC Set Speed ACC Mode ACC set distance mode Road curvature ACC Target Detected ACC System Shutoff Warning ACC Distance Alert Signal
ACC Status (65296)	J1939-X	VECU (as ACB)	Ext CAN	100 ms	(Proprietary message from ACB) Audible Following Distance Alert Visual Following Distance Alert Vehicle Following Distance Vehicle Following Interval ACB tell-tale Indicator Status
ACB Critical Events (PGN 65297)	J1939-X	VECU (as ACB)	Ext CAN	100 ms	CMT Intervention Impact Alert
AIR1	J1939-X	VECU	Ext CAN	1 second	Pneumatic Supply Pressure 46
AMB (65269)	J1939-X	VECU (as EMS)	Ext CAN	1 second	Ambient Air Temperature, Barometric pressure
AT1S (PGN 64891)	J1939-X	VECU (per reply)	Ext CAN	On Request	Diesel Particulate Filter 1 Soot Load Percent 3719 Diesel Particulate Filter 1 Ash Load Percent 3720
AT1T1I	J1939-X	VECU (as ACM)	Ext CAN	1 second	Aftertreatment 1 SCR Catalyst Tank Level 1761 Aftertreatment 1 SCR Catalyst Tank Temperature 3031 Aftertreatment 1 SCR Catalyst Tank Level 2 3517 Aftertreatment 1 DEF Tank Low-Level Indicator 5245 Aftertreatment SCR Operator Inducement Severity 5246
B	J1939-X	VECU (as IC)	Ext CAN	1 second	Brake Application Pressure (SPN 116) Brake Primary Pressure (SPN 117) Brake

SAE	CAN Network	Source of Message	Receiver of Message	Update Rate	PGN Signal Names (SPN)
					Secondary Pressure (SPN 118) Parking Brake Red Warning Signal (SPN 3557)
CCVS (65265)	J1939-X	VECU	Ext CAN	100 ms	Vehicle speed, etc.
CI (PGN 65259)	J1939-X	VECU (as EMS)	Ext CAN	On Request	Component ID, etc.
CVW (PGN 65136)	J1939-X	VECU (per reply)	Ext CAN	On Request	Weights
DD (65276)	J1939-X	VECU (as IC)	Ext CAN	1 second	Washer Fluid Level (SPN 80) Fuel Level 1 (SPN 96)
DM1	J1939-X	VECU (as received)	Ext CAN	1 second	Fault lamps, etc.
DPFC1 (PGN 64892)	J1939-X	VECU (as EMS)	Ext CAN	1 second	DPF status, etc.
EBC1 (PGN 61441)	J1939-X	VECU (as ABS)	Ext CAN	100 ms	Anti-Lock Braking (ABS) Active, etc.
EBC1 (PGN 61441)	J1939-X	Ext CAN	VECU	100 ms	Remote Accelerator Pedal Enable Switch, Accelerator Interlock Switch
EBC1 (PGN 61441)	J1939-X	VECU	Cummins	100 ms	Remote Accelerator Pedal Enable Switch (SPN 969), Accelerator Interlock Switch (SPN 972) Engine retarder selection (SPN 973)
EBC2 (WSI PGN 65215)	J1939-X	VECU (as ABS)	Ext CAN	100 ms	Wheel speeds
EBC5 (PGN 64964)	J1939-X	VECU (as ABS)	Ext CAN	100 ms	Hill Holder Mode
EEC1 (61444)	J1939-X	VECU (as EMS)	Ext CAN	As received	Engine Speed, etc
EEC2 (61443)	J1939-X	VECU	Ext CAN	50 ms	Accelerator Pedal Position
EEC2 (61443)	J1939-X	Ext CAN	VECU	50 ms	Remote Accelerator Pedal Position
EEC2 (61443)	J1939	VECU	Cummins	50 ms	Accelerator Pedal Position 1 Remote Accelerator Pedal Position
EFL/P1 (PGN 65263)	J1939-X	VECU (as EMS)	Ext CAN	500 ms	Engine Oil Level 98 Engine Oil Pressure 100 Engine Crankcase Pressure 101 Engine Coolant Level 111

SAE	CAN Network	Source of Message	Receiver of Message	Update Rate	PGN Signal Names (SPN)
ET1 (PGN 65262)	J1939-X	VECU (as EMS)	Ext CAN	1 second	Engine Coolant Temperature 110 Engine Fuel Temperature 1 174 Engine Oil Temperature 1 175
ETC1	J1939-X	VECU (as TECU)	Ext CAN	10 ms	Driveline engaged status
ETC2	J1939-X	VECU (as TECU)	Ext CAN	100 ms	Current gear status, requested gear status
ETC7	J1939-X	VECU (as TECU)	Ext CAN	100 ms	Shift and mode indicators, etc.
GFC (PGN 65199)	J1939-1	VECU (as EMS)	Ext CAN	On request	Trip Fuel (Gaseous) 1039 Total Fuel Used (Gaseous) 1040
HOURS (PGN 65253)	J1939-X	VECU (as EMS)	Ext CAN	On request	Engine Total Hours of Operation 247 Engine Total Revolutions 249
HRLFC (PGN 64777)	J1939-X	VECU (as EMS)	Ext CAN	1 second	High-Resolution Engine Trip Fuel 5053 High-Resolution Engine Total Fuel Used 5054
HRW (PGN 65134)	J1939-X	VECU (as ABS)	Ext CAN	20 ms	Wheel speeds
IO (PGN 65244)	J1939-X	VECU (as EMS)	Ext CAN	On request	Engine Total Idle Fuel Used 236 Engine Total Idle Hours 235
IC1 (PGN 65270)	J1939-X	VECU (as EMS)	Ext CAN	500 ms	Engine Exhaust Gas Temperature, etc.
LC (PGN 65089)	J1939-X	VECU (as LCM)	Ext CAN	1 second and change of state	Light switches, etc.
LC (PGN 65089)	J1939-X	VECU (as LCM)	Ext CAN	1 second and change of state	Light switches, etc.
LFC (PGN 65257)	J1939-X	VECU (as EMS)	Ext CAN	On request	Engine Trip Fuel 182 Engine Total Fuel Used 250
LFE (PGN 26266)	J1939-X	VECU (as EMS)	Ext CAN	100 ms	Engine Fuel Rate 183 Engine Instantaneous Fuel Economy 184 Engine Average Fuel Economy 185
OEL (PGN 64972)	J1939-X	VECU (as IC)	Ext CAN	1 second and change of state	Main Light Switch 2872 Turn Signal Switch 2876 Hazard Light Switch 2875 High-Low Beam Switch 2874 Operators Desired Back-light 2878
PTO (PGN 65264)	J1939-X	VECU	Ext CAN	100 ms	Power take-off Set Speed 187 Engine PTO Governor Enable Switch 980 Engine Remote PTO Governor Preprogrammed Speed Control Switch 979 Engine Remote PTO Governor Variable Speed Control Switch 978

SAE	CAN Network	Source of Message	Receiver of Message	Update Rate	PGN Signal Names (SPN)
					Engine PTO Governor Set Switch 984 Engine PTO Governor Coast/Decelerate Switch 983 Engine PTO Governor Resume Switch 982
PTODE (PGN 64932)	J1939-X	VECU (as TECU)	Ext CAN	100 ms	Engagement Consent – Transmission input shaft PTO 2 (SPN 3457) Engagement Consent – Transmission input shaft PTO 1 (SPN 3456) Engagement consent – Transmission output shaft PTO (SPN 3458)
PTODE (PGN 64932)	J1939-1	VECU	TECU, Allison	100 ms	Enable switch – Transmission input shaft PTO 2 (SPN 3453) Enable switch – Transmission input shaft PTO 1 (SPN 3452)
PTODE (PGN 64932)	J1939-1	EXT CAN	VECU	100 ms	Enable switch – Transmission input shaft PTO 2 (SPN 3453) Enable switch – Transmission input shaft PTO 1 (SPN 3452) Enable switch - PTO engine accessory drive 1
Request	J1939-X	Ext CAN	VECU		PGN
Request	J1939-1	VECU	As received	As received in most cases	PGN
SERV (PGN 65216)	J1939-X	VECU	Ext CAN	On request	Service component identification Service distance (associated to upper Service component ID) Service component identification Service delay/calendar time based (associated to upper Service component ID) Service component identification Service delay/operational time based (associated to upper Service component ID)
SOFT (PGN 65242)	J1939-1	VECU	Ext CAN	On request	Variable length
TCFG (PGN 65250)	J1939-1	VECU	Ext CAN	On request	Number of Reverse Gear Ratios 958 Number of Forward Gear Ratios 957 Transmission Gear Ratio 581
TC1 (PGN 256)	J1939-1	VECU	TECU (Allison)	50 ms (when active)	See Allison data link Communication Guide
TC1 (PGN 256)	J1939-X	VECU (as Shifter 05 and 06)	Ext CAN	50 ms (when active)	See Allison data link Communication Guide
TC1 (PGN 256)	J1939-1	Allison Shifter	VECU	50 ms (when active)	See Allison data link Communication Guide
TC1 (PGN 256)	J1939-X	EXT CAN (DA TECU)	VECU	50 ms (when active)	See Allison data link Communication Guide
TD (PGN 65254)	J1939-X	VECU (as IC)	Ext CAN	On Request	Time & date

SAE	CAN Network	Source of Message	Receiver of Message	Update Rate	PGN Signal Names (SPN)
TSC1 (PGN 0)	J1939-1	VECU	EMS	10 ms	Engine override control mode Override control mode priority Engine requested torque/torque limit Engine Requested Speed/Speed Limit 898
TSC1 (PGN 0)	J1939-1	Ext CAN (DA EMS)	VECU	10 ms	Engine override control mode Override control mode priority Engine requested torque/torque limit Engine Requested Speed/Speed Limit 898
TRF1 (PGN 65272)	J1939-X	VECU (as TECU)	Ext CAN	1 second	Transmission Oil Temperature 177, etc.
TRF2 (PGN 64917)	J1939-X	VECU (as TECU)	Ext CAN	1 second	Transmission Overheat Indicator SPN 5345
RF (PGN 65275)	J1939-X	VECU (as TECU)	Ext CAN	second	Hydraulic Retarder Oil Temperature, Driveline Retarder Overheat Indicator
VD (PGN 65248)	J1939-X	VECU (as IC)	Ext CAN	1 second	Total Vehicle Distance 245 Convert from VDHR
VDC1 (PGN 65103)	J1939-X	VECU (as ABS)	Ext CAN	100 ms	VDC Information Signal, etc.
VDHR (PGN 65217)	J1939-X	VECU (as IC)	Ext CAN	1 second	High-Resolution Total Vehicle Distance 917
VH (PGN 65255)	J1939-X	VECU	Ext CAN	On request	Total Vehicle Hours 246 Total power take-off Hours 248
VI (PGN 65260)	J1939-X	VECU (as EMS)	Ext CAN	On request	VIN
VW (PGN 65258)	J1939-X	VECU (as ECS)	Ext CAN	1 second	Weights (note this is multiframe so is difficult to respond to so will gateway at received rate)
VDC1 (PGN 65103)	J1939-X	VECU (as ACB)	Ext CAN	100 ms	VDC Information Signal, etc.
VP190 (PGN 65470)	J1939-X	VECU (as EMS)	Ext CAN	15 second	SCR used
VP60	J1939-1	VECU	TECU (I shift)	100 ms	Reverse Inhibit, Inhibit gear engaged (from TC1), PTO Conditions #1, PTO Conditions #2
VEP1 (PGN 65271)	J1939-X	VECU (as IC)	Ext CAN	1 second	SPN 168 Battery Potential/Power Input 1

Note: Although the VECU sends output messages, the source address is set as the ECU originating the information.

Note: Messages that rates “on request” are requested by the J1939 request PGN 59904 described in J1939-21. For example, requesting engine hours is done by sending EAFF or EA00 with data E5 FE 00 (hex values).

Note: Not all messages are supported on all vehicles. For example, GFC is currently not available, even for natural gas engines. However, GFC support could be available for these engines in the future.

Commands Accepted on the DL5 Body Link III Connector J1939

Message	Update Rate	Content
EBC1 (PGN 61441)	100 ms	Remote Accelerator Pedal Enable Switch Accelerator Interlock Switch
		Engine Auxiliary Shutdown: When signal is active this shall trigger an engine stop request according to parameter P1SLD. if P1SLD = 0 Engine stop from chassis function disabled P1SLD = 3 Engine stop from chassis, via SAE J1939 message SHUTDN or digital input enabled
EEC2 (61443)	50 ms	Accelerator Pedal Position 2 Remote Accelerator Pedal Position
PTODE (PGN 64932)	100 ms	Enable Switch – Transmission input shaft PTO 2 (SPN 3453) Enable Switch – Transmission input shaft PTO 1 (SPN 3452) Enable Switch - PTO Engine Accessory Drive 1
TSC1 (PGN 0) (DA EMS)	10 ms	Engine Override Control Mode 695 Engine Requested Torque/Torque Limit 518 Engine Requested Speed/Speed Limit 898
TC1 (PGN 256) (DA TECU)	50 ms (when active)	See Allison data link Communication Guide

Application Notes

By default, these commands are not accepted. To enable commands:

- P1SZL (VECU) = 1 Bridge on J-1939 for Body Builder Enable (1) Level 4 Dealer Programmable
- P1SZR (VECU) = 1 External CAN Control Enable (1) Level 4 Dealer Programmable
- P1TPZ (VECU) = 229 (Body Builder must use this Source address 229)
- A Terminating resistor for the network needs to be installed.

For safety, the accelerator and speed command signals will be overridden by a brake pedal application by default. If necessary, this options can be turned off with parameter P1SZQ. Perform a safety analysis of the application before disabling.

Although the VECU accepts these messages, the destination address (DA) needs to be 0x00 for TSC1 and 0x03 for TC1.

The engine speed command can be sent either through the accelerator command or by direct engine speed command.

Accelerator Pedal Commands

Remote Accelerator is commanded by sending **EBC1. Remote Accelerator Enable Switch** while also sending a position in **EEC2. Remote Accelerator Pedal Position**.

Primary Pedal position can be disabled by sending **EBC1. Remote Accelerator Enable Switch** without **EEC2. Remote Accelerator Pedal Position** or setting **EEC2. Remote Accelerator Pedal Position** to 0. But for clearer intent it is recommended to send **EBC1. Accelerator Interlock Switch**.

Engine Speed Commands

An engine speed command is sent by setting **TSC1. Engine Override Control Mode** to **01-Speed Control** and sending the desired speed in **SPN 898**.

SPN 898 can also represent a speed limit if **TSC1. Engine Override Control Mode** is set to **03**. Note that there are engine performance effects while operated at a limit, therefore it is recommended to disable the accelerator pedal, if that serves the intent, rather than set a limit at a command value.

Engine Torque can be limited using **TSC1. Engine Override Control Mode 02** with corresponding value in **SPN 518**.

If commands and limits are desired at the same time, **TSC1** can be repeated with different information to enable speed requests and limits at the same time since the commands will persist. Although the commands will time out if not repeated, it is recommended to end command sessions with **TSC1. Engine Override Control Mode 00** which will end all limits and commands.

PTO

mDRIVE and Allison Transmissions can accept PTODE to request PTO engagement through the “enable switch” signals. PTODE is also a response from the transmission to these requests though the “engagement consent” signals.

Source Addresses and Unit Acronyms

Control Unit	ECU	Source address (SA) or Destination Address (DA) in Hex
Engine Management System	EMS	0x00
Transmission Electronic Control Unit/ Control Module	TECU/TCM	0x03
Anti-lock Brake System	ABS	0x0B

Control Unit	ECU	Source address (SA) or Destination Address (DA) in Hex
Gear Shift Electronic Control Unit	GSECU	0x05 (0x06 for right side on LR)
Engine Brake	EB	0x0F
Vehicle Electronic Control Unit	VECU	0x11
Instrument Cluster	IC	0x17
Adaptive Cruise with Braking function	ACB	0x2A
Electronically Controlled Suspension	ECS	0x2F
Aftertreatment Control Module	ACM	0x3D

Support Inbound and Outbound DL1 J-1939 Message Information

Note: MACK does not recommend broadcasting on the data bus. However, it is known that there are devices on the market which affect an engine speed control. MACK broadcasts the following with message and signal definition per SAE J1939-71.

Instrument Cluster

Message	Bus	From ECU	To ECU	Update Rate	Content
B (65274)	J1939-1	IC	VECU	1 s	Brake Application Pressure (SPN 116) Brake Primary Pressure (SPN 117) Brake Secondary Pressure (SPN 118) Parking Brake Red Warning Signal (SPN 3557)
CL (53248)	J1939-1	IC	VECU	5 s and state change	Illumination Brightness Percent (SPN 1487)
CM1 (57344)	J1939-1	IC	VECU	1 s	Seat Belt Switch (SPN 1856) Diesel Particulate Filter Regeneration Inhibit Switch (SPN 3695) Diesel Particulate Filter Regeneration Force Switch (SNP 3696)
DD (65276)	J1939-1	IC	VECU	1 s	Washer Fluid Level (SPN 80) Fuel Level 1 (SPN 96)
LC (PGN 65089)	J1939-1	IC	VECU	1 s and change of state	Low Beam Headlight Command 2349 High Beam Headlight Command 2347 Right Turn Signal Lights Command 2369 Left Turn Signal Lights 2367 Rotating Beacon Light Command (Hazard) 2385
OEL (PGN 64972)	J1939-1	IC	VECU	1 s and change of state	Main Light Switch 2872 Turn Signal Switch 2876 Hazard Light Switch 2875 High-Low Beam Switch 2874 Operators Desired Back-light 2878
TD (PGN 65254)	J1939-1	IC	VECU	1 s	Time & date
VEP1 (PGN 65271)	J1939-1	IC	VECU	1 s	SPN 168 Battery Potential/Power Input 1
VDHR (PGN 65217)	J1939-1	IC	VECU	1 s	High-Resolution Total Vehicle Distance 917

ACC/ABS

Message	Bus	From ECU	To ECU	Update Rate	Content
ACC1 (PGN 65135)	J1939-1	ACB (0x2A)	VECU	100 ms	Forward Vehicle Speed Forward Vehicle Distance ACC Set Speed ACC Mode ACC Set Distance Mode Road Curvature ACC Target Detected ACC System Shutoff Warning ACC Distance Alert Signal
ACC Status (PGN 65296)	J1939-1	ACB	VECU	100 ms	(Proprietary message from ACB) Audible Following Distance Alert Visual Following Distance Alert Vehicle Following Distance Vehicle Following Interval ACB tell-tale Indicator Status
ACB Critical Events (PGN 65297)	J1939-1	ACB	VECU	100 ms	CMT Intervention Impact Alert
EBC5 (PGN 64964)	J1939-1	ABS	VECU	100 ms	Hill Holder Mode
EBC1 (PGN 61441)	J1939-1	ABS	VECU	100 ms	Anti-Lock Braking (ABS) Active, etc.
EBC2 (WSI PGN 65215)	J1939-1	ABS	VECU	100 ms	Wheel speeds
HRW (PGN 65134)	J1939-1	ABS	VECU	20 ms	Wheel speeds
VDC1 (PGN 65103)	J1939-1	ABS	VECU	100 ms	VDC Information Signal, etc.

EMS/ACM

Message	Bus	From ECU	To ECU	Update Rate	Content
AT1T1I	J1939-1	EMS	VECU	1 s	Aftertreatment 1 DEF Tank Low-Level Indicator 5245 Aftertreatment SCR Operator Inducement Severity 5246
AT1T1I	J1939-1	ACM	VECU	1 s	Aftertreatment 1 SCR Catalyst Tank Level 1761 Aftertreatment 1 SCR Catalyst Tank Temperature 3031 Aftertreatment 1 SCR Catalyst Tank Level 2 3517
AT1S (PGN 64891)	J1939-1	EMS	VECU	On Request (1 s)	Diesel Particulate Filter 1 Soot Load Percent 3719 Diesel Particulate Filter 1 Ash Load Percent 3720
CI (PGN 65259)	J1939-1	EMS	VECU	10 s	Component ID, etc.

Message	Bus	From ECU	To ECU	Update Rate	Content
DPFC1 (PGN 64892)	J1939-1	EMS	VECU	1 s	DPF status, etc
EEC1 (61444)	J1939-1	EMS	VECU	20 ms Variable?	Engine Speed, etc
ET1 (PGN 65262)	J1939-1	EMS	VECU	1 s	Engine Coolant Temperature 110 Engine Fuel Temperature 1 174 Engine Oil Temperature 1 175
EFL/P1 (PGN 65263)	J1939-1	EMS	VECU	500 ms	Engine Oil Level 98 Engine Oil Pressure 100 Engine Crankcase Pressure 101 Engine Coolant Level 111
ERC1 (PGN 61440)	J1939-1	EMS (as retarder)	VECU	100 ms	Retarder Torque Mode 900 Actual Retarder - Percent Torque 520 Etc.
IC1 (PGN 65270)	J1939-1	EMS	VECU	500 ms	Engine Intake Manifold #1 Pressure 102 Engine Intake Manifold 1 Temperature 105 Engine Air Intake Pressure 106 Engine Exhaust Gas Temperature 173
IO (PGN 65244)	J1939-1	EMS	VECU	On Request (1 s)	Engine Total Idle Fuel Used 236 Engine Total Idle Hours 235
GFC (PGN 65199)	J1939-1	EMS	VECU	Currently Not Supported	Trip Fuel (Gaseous) 1039 Total Fuel Used (Gaseous) 1040
HRLFC (PGN 64777)	J1939-1	EMS	VECU	1 s	High-Resolution Engine Trip Fuel 5053 High Engine Total Fuel Used 5054
HOURS (PGN 65253)	J1939-1	EMS	VECU	15 s (on request)	Engine Total Hours of Operation 247 Engine Total Revolutions 249
LFE (PGN 26266)	J1939-1	EMS	VECU	100 ms	Engine Fuel Rate 183 Engine Instantaneous Fuel Economy 184 Engine Average Fuel Economy 185
LFC (PGN 65257)	J1939-1	EMS	VECU	On request (1 s)	Engine Trip Fuel 182 Engine Total Fuel Used 250
VI (PGN 65260)	J1939-1	EMS	VECU	On request (3 s)	VIN

VECU

Message	Bus	From ECU	To ECU	Update Rate	Content
AIR1	J1939-X	VECU	Ext CAN	1 s	Pneumatic Supply Pressure 46
AMB (65269)	J1939-X	VECU (as EMS)	Ext CAN	1 s	Ambient Air Temperature Barometric pressure
AT1S (PGN 64891)	J1939-X	VECU (per reply)	Ext CAN	On Request	Diesel Particulate Filter 1 Soot Load Percent 3719 Diesel Particulate Filter 1 Ash Load Percent 3720
AT1T1I	J1939-X	VECU (as ACM)	Ext CAN	1 s	Aftertreatment 1 SCR Catalyst Tank Level 1761 Aftertreatment 1 SCR Catalyst Tank Tempera- ture 3031

Message	Bus	From ECU	To ECU	Update Rate	Content
					Aftertreatment 1 SCR Catalyst Tank Level 2 3517 Aftertreatment 1 DEF Tank Low-Level Indicator 5245 Aftertreatment SCR Operator Inducement Severity 5246
B	J1939-X	VECU (as IC)	Ext CAN	1 s	Brake Application Pressure (SPN 116) Brake Primary Pressure (SPN 117) Brake Secondary Pressure (SPN 118) Parking Brake Red Warning Signal (SPN 3557)
CCVS (65265)	J1939-X	VECU	Ext CAN	100 ms	Vehicle Speed, etc.
CI (PGN 65259)	J1939-X	VECU (as EMS)	Ext CAN	On Request	Component ID, etc.
CVW (PGN 65136)	J1939-X	VECU (per reply)	Ext CAN	1 s	Weights
DD (65276)	J1939-X	VECU (as IC)	Ext CAN	1 s	Washer Fluid Level (SPN 80) Fuel Level 1 (SPN 96)
DM1	J1939-X	VECU (as received)	Ext CAN	1 s	Fault lamps, etc.
DPFC1 (PGN 64892)	J1939-X	VECU (as EMS)	Ext CAN	1 s	DPF status, etc.
EBC1 (PGN 61441)	J1939-X	VECU (as ABS)	Ext CAN	100 ms	Anti-Lock Braking (ABS) Active, etc.
EBC1 (PGN 61441)	J1939-X	Ext CAN	VECU	100 ms	Remote Accelerator Pedal Enable Switch Accelerator Interlock Switch
EBC1 (PGN 61441)	J1939-X	VECU	Cummins	100 ms	Remote Accelerator Pedal Enable Switch (SPN 969) Accelerator Interlock Switch (SPN 972) Engine retarder selection (SPN 973)
EBC2 (WSI PGN 65215)	J1939-X	VECU (as ABS)	Ext CAN	100 ms	Wheel Speeds
EBC5 (PGN 64964)	J1939-X	VECU (as ABS)	Ext CAN	100 ms	Hill Holder Mode
EEC1 (61444)	J1939-X	VECU (as EMS)	Ext CAN	As received	Engine Speed, etc
EEC2 (61443)	J1939-X	VECU	Ext CAN	50 ms	Accelerator Pedal Position
EEC2 (61443)	J1939-X	Ext CAN	VECU	50 ms	Remote Accelerator Pedal Position
EEC2 (61443)	J1939	VECU	Cummins	50 ms	Accelerator Pedal Position 1 Remote Accelerator Pedal Position
EFL/P1 (PGN 65263)	J1939-X	VECU (as EMS)	Ext CAN	500 ms	Engine Oil Level 98 Engine Oil Pressure 100

Message	Bus	From ECU	To ECU	Update Rate	Content
					Engine Crankcase Pressure 101 Engine Coolant Level 111
ET1 (PGN 65262)	J1939-X	VECU (as EMS)	Ext CAN	1 s	Engine Coolant Temperature 110 Engine Fuel Temperature 1 174 Engine Oil Temperature 1 175
ETC1	J1939-X	VECU (as TECU)	Ext CAN	10 ms	Driveline engaged status
ETC2	J1939-X	VECU (as TECU)	Ext CAN	100 ms	Current Gear Status Requested gear status
ETC7	J1939-X	VECU (as TECU)	Ext CAN	100 ms	Shift and mode indicators, etc.
GFC (PGN 65199)	J1939-1	VECU (as EMS)	Ext CAN	On Request	Trip Fuel (Gaseous) 1039 Total Fuel Used (Gaseous) 1040
HOURS (PGN 65253)	J1939-X	VECU (as EMS)	Ext CAN	On Request	Engine Total Hours of Operation 247 Engine Total Revolutions 249
HRLFC (PGN 64777)	J1939-X	VECU (as EMS)	Ext CAN	1 s	High-Resolution Engine Trip Fuel 5053 High Engine Total Fuel Used 5054
HRW (PGN 65134)	J1939-X	VECU (as ABS)	Ext CAN	20 ms	Wheel speeds
IO (PGN 65244)	J1939-X	VECU (as EMS)	Ext CAN	On Request	Engine Total Idle Fuel Used 236 Engine Total Idle Hours 235
IC1 (PGN 65270)	J1939-X	VECU (as EMS)	Ext CAN	500 ms	Engine Exhaust Gas Temperature, etc
LC (PGN 65089)	J1939-X	VECU (as LCM)	Ext CAN	1 s and change of state	Light switches, etc.
LFE (PGN 26266)	J1939-X	VECU (as EMS)	Ext CAN	100 ms	Engine Fuel Rate 183 Engine Instantaneous Fuel Economy 184 Engine Average Fuel Economy 185
OEL (PGN 64972)	J1939-X	VECU (as IC)	Ext CAN	1 s and change of state	Main Light Switch 2872 Turn Signal Switch 2876 Hazard Light Switch 2875 High-Low Beam Switch 2874 Operators Desired Back-light 2878
PTO (PGN 65264)	J1939-X	VECU	Ext CAN	100 ms	Power take-off Set Speed 187 Engine PTO Governor Enable Switch 980 Engine Remote PTO Governor Preprogrammed Speed Control Switch 979 Engine Remote PTO Governor Variable Speed Control Switch 978 Engine PTO Governor Set Switch 984 Engine PTO Governor Coast/Decelerate Switch 983 Engine PTO Governor Resume Switch 982

Message	Bus	From ECU	To ECU	Update Rate	Content
PTODE (PGN 64932)	J1939-X	VECU (as TECU)	Ext CAN	100 ms	Engagement Consent – Transmission input shaft PTO 2 (SPN 3457) Engagement Consent – Transmission input shaft PTO 1 (SPN 3456) Engagement Consent – Transmission output shaft PTO (SPN 3458)
PTODE (PGN 64932)	J1939-1	VECU	TECU, Allison	100 ms	Enable Switch – Transmission input shaft PTO 2 (SPN 3453) Enable Switch – Transmission input shaft PTO 1 (SPN 3452)
PTODE (PGN 64932)	J1939-1	Ext CAN	VECU	100 ms	Enable Switch – Transmission input shaft PTO 2 (SPN 3453) Enable Switch – Transmission input shaft PTO 1 (SPN 3452) Enable Switch - PTO Engine Accessory Drive 1
Request	J1939-X	Ext CAN	VECU		PGN
Request	J1939-1	VECU	As received	As received in most cases	PGN
SERV (PGN 65216)	J1939-X	VECU	Ext CAN	On Request	Service Component Identification Service Distance (associated to upper Service component ID) Service Component Identification Service delay/calendar time based (associated to upper Service component ID) Service Component Identification Service Delay/Operational Time Based (associated to upper Service component ID)
SOFT (PGN 65242)	J1939-1	VECU	Ext CAN	On Request	Variable length
TCFG (PGN 65250)	J1939-1	VECU	Ext CAN	On Request	Number of Reverse Gear Ratios 958 Number of Forward Gear Ratios 957 Transmission Gear Ratio 581
TC1 (PGN 256)	J1939-1	VECU	TECU (Allison)	50 ms (when active)	See Allison data link Communication Guide
TC1 (PGN 256)	J1939-X	VECU (as Shifter 05 and 06)	Ext CAN	50 ms (when active)	See Allison data link Communication Guide
TC1 (PGN 256)	J1939-1	Allison Shifter	VECU	50 ms (when active)	See Allison data link Communication Guide
TC1 (PGN 256)	J1939-X	EXT CAN (DA TECU)	VECU	50 ms (when active)	See Allison data link Communication Guide
TD (PGN 65254)	J1939-X	VECU (as IC)	Ext CAN	On Request	Time & date
TSC1 (PGN 0)	J1939-1	VECU	EMS	10 ms	Engine Override Control Mode Override Control mode Priority Engine Requested Torque/Torque Limit Engine Requested Speed/Speed Limit 898

Message	Bus	From ECU	To ECU	Update Rate	Content
TSC1 (PGN 0)	J1939-1	Ext CAN (DA EMS)	VECU	10 ms	Engine Override Control Mode Override Control Mode Priority Engine Requested Torque/Torque Limit Engine Requested Speed/Speed Limit 898
TRF1 (PGN 65272)	J1939-X	VECU (as TECU)	Ext CAN	1 s	Transmission Oil Temperature 177, etc.
TRF2 (PGN 64917)	J1939-X	VECU (as TECU)	Ext CAN	1 s	Transmission Overheat Indicator SPN 5345
RF (PGN 65275)	J1939-X	VECU (as TECU)	Ext CAN	1 s	Hydraulic Retarder Oil Temperature Driveline Retarder Overheat Indicator
VD (PGN 65248)	J1939-X	VECU (as IC)	Ext CAN	1 s	Total Vehicle Distance 245 Convert from VDHR
VDC1 (PGN 65103)	J1939-X	VECU (as ABS)	Ext CAN	100 ms	VDC Information Signal, etc.
VDHR (PGN 65217)	J1939-X	VECU (as IC)	Ext CAN	1 s	High-Resolution Total Vehicle Distance 917
VH (PGN 65255)	J1939-X	VECU	Ext CAN	On Request	Total Vehicle Hours 246 Total power take-off Hours 248
VI (PGN 65260)	J1939-X	VECU (as EMS)	Ext CAN	On Request	VIN
VW (PGN 65258)	J1939-X	VECU (as ECS)	Ext CAN	1 s	Weights (note this is multiframe so is difficult to respond to so will gateway at received rate)
VDC1 (PGN 65103)	J1939-X	VECU (as ACB)	Ext CAN	100 ms	VDC Information Signal, etc.
VP190 (PGN 65470)	J1939-X	VECU (as EMS)	Ext CAN	15 s	SCR used
VP60	J1939-1	VECU	TECU (I-Shift)	100 ms	Reverse Inhibit Inhibit Gear Engaged (from TC1) PTO Conditions #1 PTO Conditions #2
VEP1 (PGN 65271)	J1939-X	VECU (as IC)	Ext CAN	1 s	SPN 168 Battery Potential/Power Input 1

Transmission

Message	Bus	From ECU	To ECU	Update Rate	Content
ETC1	J1939-1	Automated Trans	VECU	10 ms	Driveline engaged status
ETC2	J1939-1	Automated Trans	VECU	100 ms	Current gear status, requested gear status
ETC7	J1939-1	Allison	VECU	100 ms	Range Display, Mode indicator
PTODE (PGN 64932)	J1939-1	TECU (I-Shift)	VECU	100 ms	Engagement Consent – Transmission input shaft PTO 2 (SPN 3457) Engagement Consent – Transmission input shaft PTO 1 (SPN 3456)

Message	Bus	From ECU	To ECU	Update Rate	Content
PTODE (PGN 64932)	J1939-1	TECU (Allison)	VECU	100 ms	Engagement Consent – Transmission input shaft PTO 2 (SPN 3457) Engagement Consent – Transmission input shaft PTO 1 (SPN 3456) Engagement Consent – Transmission output shaft PTO (SPN 3458)
PTODE (PGN 64932)	J1939-1	VECU, EXT CAN (SA 33, SA 23)	TECU (Allison)	100 ms	Enable Switch – Transmission input shaft PTO 2 (SPN 3453) Enable Switch – Transmission input shaft PTO 1 (SPN 3452) Engagement Consent – Transmission output shaft PTO (SPN 3458)
SOFT (PGN 65242)	J1939-1	Allison	VECU	On Request	Variable Length
TranTC1 (256)	J1939-1	EXT CAN, Allison Shifter	TECU (Allison)	50 ms (when active)	See Allison data link Communication Guide
TCFG (PGN 65250)	J1939-1	Allison	VECU	On Request	Number of Reverse Gear Ratios 958 Number of Forward Gear Ratios 957 Transmission Gear Ratio 581
TRF1 (PGN 65272)	J1939-1	Automated Trans	VECU	1 s	Transmission Oil Temperature 177, etc.
TRF2 (PGN 64917)	J1939-1	Allison	VECU	1 s	Transmission Overheat Indicator SPN 5345
RF (PGN 65275)	J1939-1	Allison	VECU	1 s	Hydraulic Retarder Oil Temperature Driveline Retarder Overheat Indicator
VP60	J1939-1	VECU	I-Shift	100 ms	Inhibit Gear Engaged Reverse Inhibit PTO Conditions #1 PTO Conditions #2

ECS

Message	Bus	From ECU	To ECU	Update Rate	Content
VW (PGN 65258)	J1939-X	ECS	VECU	1 second (SAE says On Request)	Weight by axle (1 frame for each axle)

Parameters Description and Location

Caption Description	Location	Resolution	Min Value	Max Value	Default	Parameter ID
Enables the Vehicle Electronic Control Unit (VECU) to accept body commands from devices on the Bodybuilder CAN.	VECU	1	0	1	0	Level 4 P1SZR
Enables gateway of messages from J1939-1 bus to DL5 bus. Note: This parameter is to only be updated when third party telematics is installed on the vehicle.	VECU	1	0	1	0 (set to 1 per project)	Level 4 P1SZL
SA for device (Note F1 & F9 SA for TSC1, PTODE, VP45, EEC2, EBC1) If a device on the Ext CAN will request messages or send commands to the truck then this needs to reflect the source address of the added device. Also set P1SZR Take note of P1SZQ	VECU	1	0	255	229	Level 4 P1TPZ (Scalar 2)
SA for device (Note F1SA for TC1) If a device on the Ext CAN is to broadcast TC1 commands then this needs to be set to what the transmission will accept and the device needs to send with this source address. However this cannot be the same as any on-vehicle shifter broadcasting per P1TPZ. Also set parameter P1SZR.	VECU	1	0	255	6	Level 4 P1TPZ (Scalar 4)
SA for GFC (Note: F4 SA of message used to respond to device request) This parameter should reflect the source address of the vehicle device responding to a request for message GFC.	VECU	1	0	255	0	Level 4 P1TPZ (Scalar 3)
SA for CVW	VECU	1	0	255	3	Level 4 P1TPZ (Scalar 1)
SA for TCFG (Note: F4 SA) This parameter should reflect the source address of the vehicle device responding to a request for message TCFG.	VECU	1	0	255	3	Level 4 P1TPZ (Scalar 6)
SA for TC1 (Note: F2 SA) This parameter should reflect the source address of the vehicle device supplying message TC1	VECU	1	0	255	5	Level 4 P1TPZ (Scalar 5)
Ext CAN Break Pedal Override If this parameter is set then Ext CAN accelerator pedal position and engine speed commands will be set to idle while the service brake is pressed.	VECU	1	0	255	1	Level 4 P1SZQ

Notes

Road-Speed Reader Kit

Note: This kit is no longer needed with the IC-GEN2 instrument cluster for trucks built September 2023-Current. Road speed signal can be received from the X156 connector under the FRC pie plate. Parameter P13NU should be set to 2.

Note: For the trucks with GEN-2 interiors, to obtain a road speed signal through the J-1939 CAN Bus, the road-speed reader kit (part number– 23584420) is required . It is required for Conventional trucks with mDRIVE and Mack Manual Transmissions. This kit is available through Mack parts system.

Note: Mack Trucks now installs the kit at the plant when one of the following variants are ordered:
 L3X-A3X (BBM connector 29 pin BOC, 9 pin under passenger seat and speed sense connector)
 L3X-A5X (BBM connector 29 pin BOC and speed sense connector)
 L3X-B9X (Electrical body builder preparation kit, 9 pin under passenger seat and speed sense connector)

Variant	Description	Sales Code
L3X-A3X	BBM connector 29 pin BOC, 9 pin under passenger seat and speed sense connector	B831026
L3X-A5X	BBM connector 29 pin BOC and speed sense connector	B831027
L3X-B9X	Electrical body builder preparation kit, 9 pin under passenger seat and speed sense connector	B831028

Installation for Road Speed Reader Kit

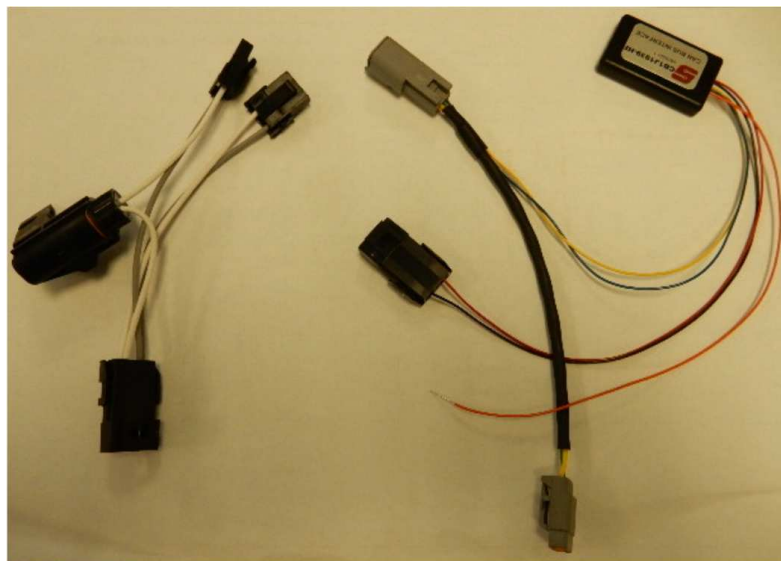

W3140107

Fig. 37 Road Speed Reader Kit

Note: The road-speed reader kit (part number– 23584420) is not required if your truck has an Allison transmission. Allison provides a road speed signal at the Allison Body Builder connector located left of the steering column, and behind the kick panel. The road speed signal is sent through the wire # N125, Pin F of the connector. (See Connector Below)



W3140108

Fig. 38 Allison Body Builder Connector

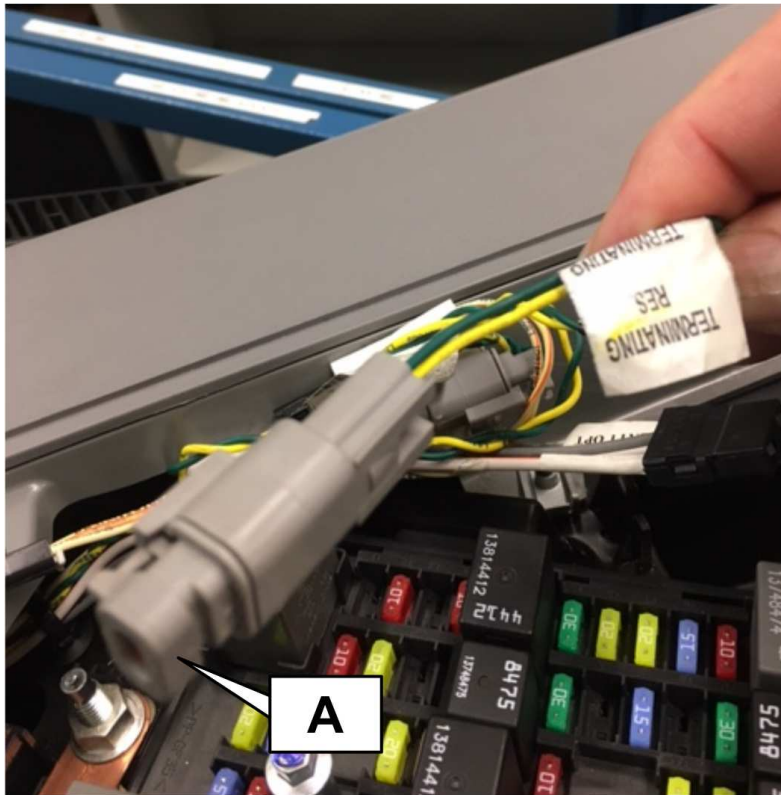

W3140109

Fig. 39 Terminating resistor

A - Find the terminating resistor under the pie plate at Fuse relay panel and remove the terminating resistor.

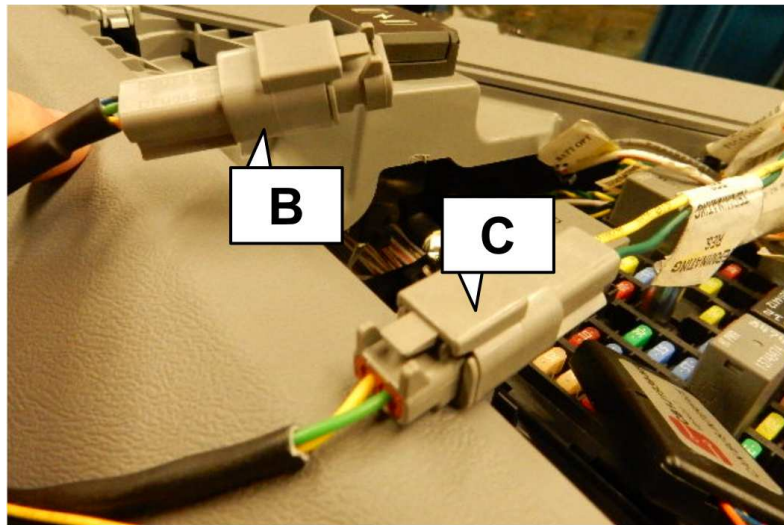

W3140110

Fig. 40 Connecting the CAN Bus reader

B – Insert terminating resistor in the female connector on the CAN Bus reader cable.

C – Plug in the CAN Bus cable male connector in the female connector on the truck cab harness term resistor connector.

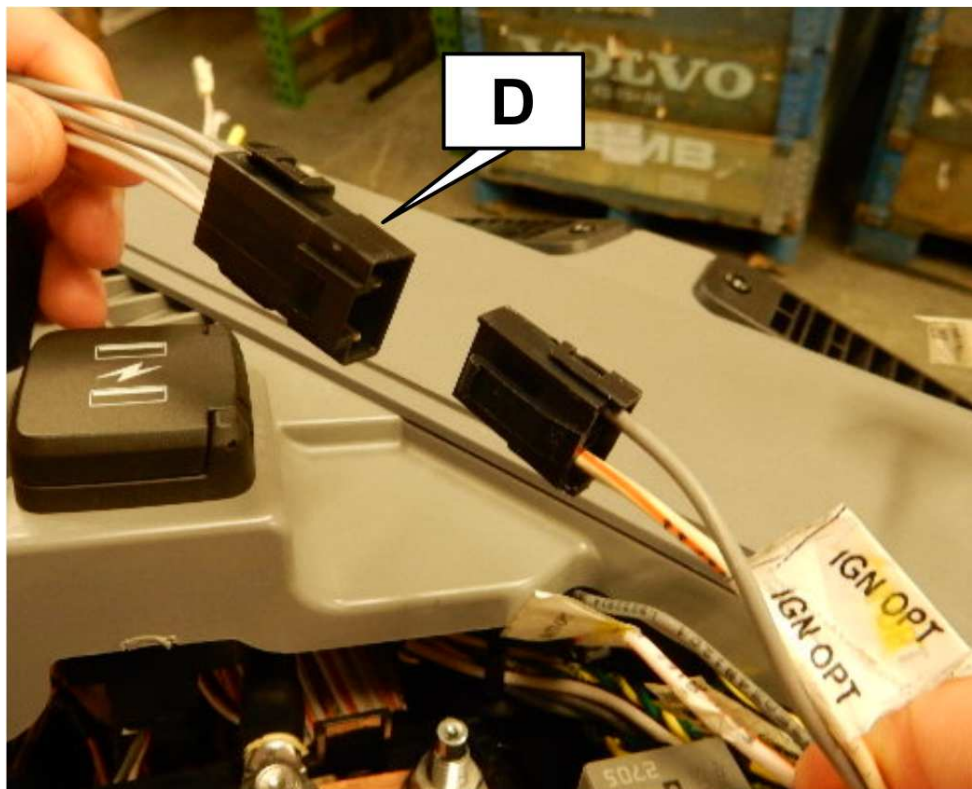

W3140111

Fig. 41 IGN OPT connector

D – Connect the female Y power harness connector to the male IGN OPT connector

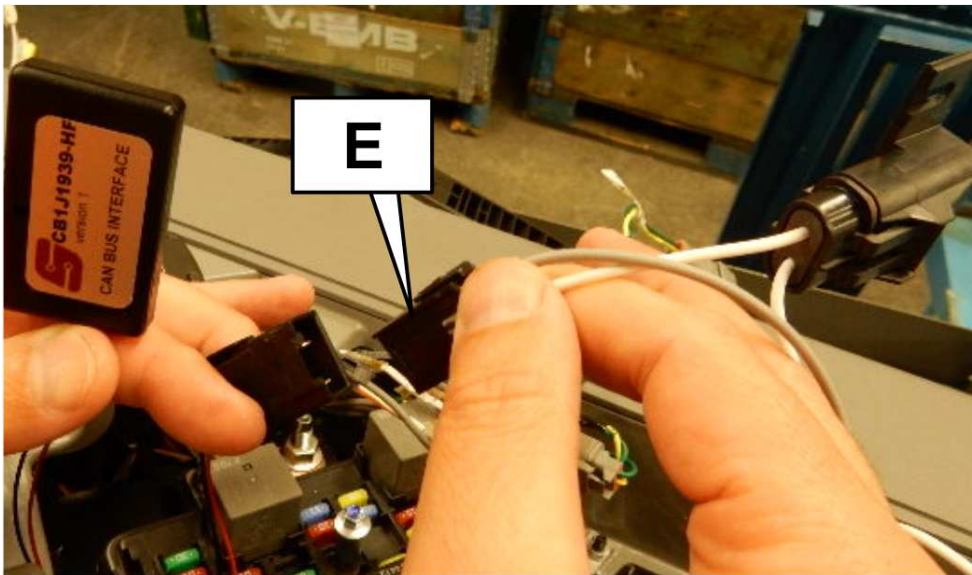

W3140112

Fig. 42 Connecting the CAN Bus reader

E – Connect the male connector of the power harness to the female power connector on the CAN Bus reader (fused side).

Note: The other leg of the power harness is for another ignition option.



W3140113

Fig. 43 CAN Bus reader installed

Secure with cable ties. Installation is complete. This is what it should look like when completed.

Note: The orange wire is the road speed output for your device.

Note: The CAN Bus reader produces a 12-volt speed pulse of 8000 ppm.

Note: After the installation of CAN Bus, check the LED indicators on the device.

Stage 1: Both Green and Red LEDs will lit approximately for 1 second

Stage 2: Green LED will lit while listening for data

Stage 3: Red LED indicates CAN has been detected

Stage 4: Green LED should pulse when vehicle is driven. Red LED should stay on

Troubleshoot

If the CAN bus is installed and the LED's are not lit as indicated, follow the procedure to troubleshoot:

- 1 Check power and ground to the device
- 2 Check that the terminating resistor is connected to the female connector of the device
- 3 Check that the J1939 connector wires (green and yellow) are plugged to the truck. Ensure that the wires are match on both sides of the connectors. (refer Figure. 40 connector C)
- 4 If the device does not produce the ground speed signal, contact body builder support 1-877-770-7575.

Sensata Technologies PreView System (Passive Safety System)

Note: PreView System Is only applicable for TE, LR and LRBE models.

Mack Trucks now offers a Sensata Technologies PreView® Radar System as an option for TE, LR and LRBE models.

The PreView System is a driver alert system that uses radar to detect the objects nearer to the vehicle.

PreView System includes

- 1 PreView Sentry® sensor / Front View Support System (FVSS) (1 quantity)
- 2 PreView Sentry® sensor / Rearward Support System (RWSS) (1 quantity)
- 3 PreView Side Defender®II sensors / Mitigate Turn Collision Support (MTCS) System (2 quantity — one on each side)
- 4 PreView® In-cab LED (Light Emitting Diode) displays (2 quantity — One on each A-Pillar).

Note: The FVSS sensor and In-cab LED display are factory installed. RWSS (1 quantity) and MTCS (2 quantity) are included in the KIT.

Note: For more information refer Owner's manual.

General Guidelines For Sensor Installation

- Read the entire document before beginning the installation of the sensors on the vehicle.
- Installation, mounting and electrical connection only be carried out by a trained specialist in accordance with the information in the document.
- Sensor mounting location is the critical part while installing and for the proper operation of the system.
- To have an unobstructed FOV (Field Of View) and to cover the targeted blind spots, select the location at an appropriate height where the sensor gets protection from impact and debris.
- Verify that the selected location provides a clear detection zone before the sensor is installed permanently on the vehicle.
- Install the sensor temporarily on the selected location and take the vehicle to an open field with no object in the detection zone. Activate the system and verify that nothing has been detected.
- When any sensor is mounted outside the given sensor tolerance zone, the sensor performance test has to be carried out to ensure signal accuracy.

Sensor Model Numbering System

Example: Model ST8XYYZ-M

X— Connector type (7 is for Deutsch and 2 is for Conxall)

YY— Sensor detection range in meters (0-30 m)

X— Sensor detection width in meters (3 m).

M— Mounting location on the vehicle

Example: ST87063-12 It describes a sensor with a Deutsch connector, 6 m (20') detection range, 3 m (10') detection width and (12) mounting location of the sensor is front of the vehicle (for rear 6, for RH side 3 and for LH side 9)

PreView Sentry® Sensor (Front View Support System And Rearward Support System)

The FVSS and RWSS are FMCW (Frequency Modulated Continuous Waveform) radar object detection sensor designed to alert equipment (vehicle, truck, machine) operators to the presence of objects. The sensor detects both moving and stationary objects in a pre-defined coverage area and can report the distance of the closest object via the In-cab LED displays.

- The front sensor model number is ST87033-12
- The rear sensor model number is ST87063-6.

The FVSS detects the obstacles in the front of the vehicle and the RWSS detects the obstacles in the rear of the vehicle. The FVSS and RWSS process and report detections to the driver through the In-cab LED display. The sensors communicate with the In-cab display using a CAN interface as specified in ISO 11898-2. The CAN bus operates at 250 kbit/s and is not terminated in the sensor.

CAN is a standard communication interface, the sensor can be connected to other CAN controllers, telematics interfaces, displays, etc. Sensors comes equipped with a Deutsch connector (ST87 series) pigtail harness terminated or a Conxall Connector (ST82 Series).

Component Location

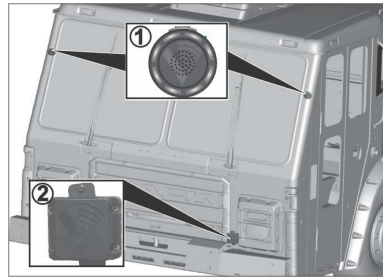

T3181873

Fig. 44 FVSS and In-cab LED Display

- 1 In-cab LED Display
- 2 Sensor, Front View Support System (FVSS).

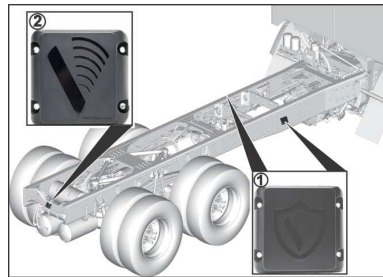

T3181874

Fig. 45 RWSS and MTCS

- 1 Sensor, Mitigate Turn Collision Support (MTCS) System (2 numbers)
- 2 Sensor, Rearward Support System (RWSS).

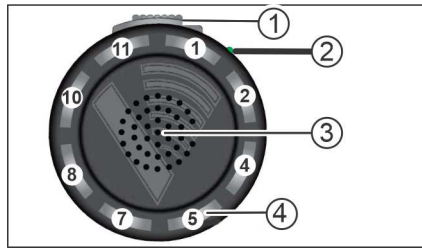

T3181875

Fig. 46 In-cab LED Display

- 1 Volume/Acknowledge Button
- 2 Status LED
- 3 Speaker
- 4 Detection LEDs.

In-cab LED Display System Operation

The left A-pillar LED display will report the detection(s) of object(s) from the front, left and rear sensors. The right A-pillar display will report the detection(s) of object(s) from the front, right and rear sensors.

Sensor Mounting Tolerance (Sentry Radar Sensor)

Note: To have an unobstructed FOV (Field Of View) and to cover the targeted blind spots, select the location at an appropriate height where the sensor gets protection from impact and debris. Below values are valid for both FVSS and RWSS.

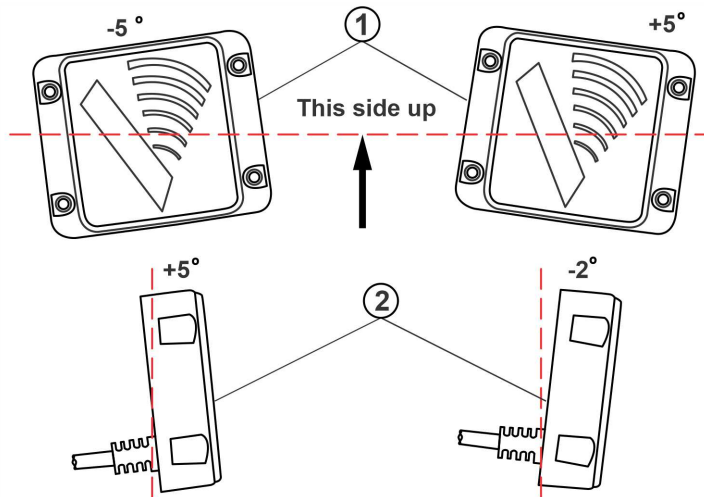

T3181880

Fig. 47 FVSS & RWSS Sensor

- 1 Horizontal Angle Tolerance
- 2 Vertical Angle Tolerance.

Note: When the mounting height is higher than 1.3 m (4 feet), the sensor can be angled down to few degrees (less than 5°). The performance of the sensor can be negatively impacted if the sensor is angled down (more than 5°) causing false detection.

SL NO	Description	Value
1	Height tolerance (from the ground)	1±0.3 m (36", ±12")
2	Vertical angle tolerance Up / Down	+5° / -2°

3	Horizontal angle tolerance	±5°
4	Sensor connector and mating connector (For Deutsch model)/ (For Conxall model) drill the hole of diameter	38 mm (1½ ") / 24 mm (1")
5	Sensor mounting hole	6 mm (¼")
6	Torque to Secure the sensor	2.5 Nm (22 in-lbs)
7	Horizontal field of view	±75° (150°)
8	Vertical field of view	±10°

PreView Side Defender®II Sensors (Mitigate Turn Collision Support System)

The MTCS is a FMCW (Frequency Modulated Continuous Waveform) radar object detection sensor designed to alert drivers of medium and heavy-duty vehicles to the presence of obstacle, vulnerable road users (VRUs) in their blind zone and other moving vehicles on the left and right-hand sides of the vehicle. If the MTCS detects any moving object or any potential collision threat, it alerts and reports to the driver through an in-cab LED driver display.

- The right-side sensor model number is SDII8703-3
- The left side sensor model number is SDII8709-9.



WARNING

If the PreView Electronics® system is not wired properly, it may not operate as intended, which may result in a failure to warn the operator of a hazardous situation.

Do not connect the sensor directly to the vehicle CAN bus. Always use a gateway, such as the In- cab LED display designed to ensure that the connection allows one-way communication only from the vehicle CAN bus to the sensor. Do not allow the messages to be transmitted from sensor J1939 CAN to the vehicle CAN bus.

Note: If using a gateway to the vehicle CAN bus for the speed message, the vehicle CAN bus, Sensor and in-cab LED display must all use the same baud rate.

At speed of 30 km/h (19 mph) or less, the MTCS alerts the driver about the VRUs in the detection zone. It also alerts the driver about the vehicles moving in the adjacent lane when the vehicle speed is above 30 km/h (19 mph). Stationary objects such as guardrails or concrete barriers are ignored to minimize nuisance alerts. It optimizes the blind zone collision mitigation during a lane change or merging.

The MTCS requires a turn signal and reverse signal inputs for the proper operation of the in-cab LED display. When the turn signal is activated and an obstacle is detected, the in-cab LED display notifies the driver with both audible and visual alerts.

Sensor Mounting Tolerance (Side Defender II Radar Sensor)

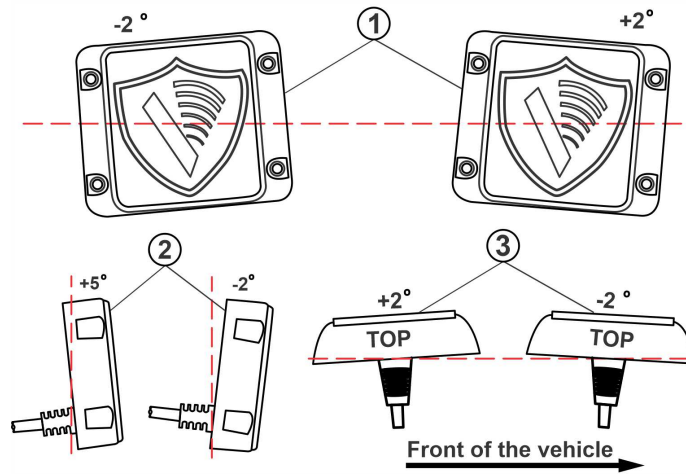

T3181886

Fig. 48 MTCS Sensor

- 1 Horizontal Angle Tolerance (fore and aft)
- 2 Vertical Angle Tolerance
- 3 Horizontal Angle Tolerance (side/side).

Note: The performance of the sensor can be negatively impacted if the sensor is angled down more than the recommended value causing false detection.

Sensor Mounting Location On The Vehicle

Mount the sensor at an appropriate height so that sensor detection covers all blind spots. For proper operation of the sensor, the sensor face has to be perpendicular to the ground, properly oriented, text up and V Logo pointing down as shown in the illustration.

Install the MTCS sensor on the vehicle side with the bottom of the radar no lower than 60 cm (23"). The radar's top is no more than 100 cm (39") above the ground. Between 350 cm (137") and 500 cm (197") back from the vehicle front edge.

Note: To have an unobstructed FOV (Field Of View) and to cover the targeted blind spots, select the location at an appropriate height where the sensor gets protection from impact and debris. Refer to the Keep Out zones / Interference Zones

SL NO	Description	Value
1	Height tolerance (from the ground)	Greater than 60 cm and Less than 100 cm
2	Vertical angle tolerance Up / Down	+5° / -2°
3	horizontal angle tolerance (side/side)	±2°
4	Horizontal angle tolerance (fore/aft)	±2°
5	Sensor connector and mating connector (For Deutsch model)/ (For Conxall model) drill the hole of diameter	38 mm (1½ ") / 24 mm (1")
6	Sensor mounting hole	6 mm (¼")
7	Torque to Secure the sensor	2.5 Nm (22 in-lbs)
8	Horizontal field of view	±75° it can be up to ±85°
9	Vertical field of view	±10°

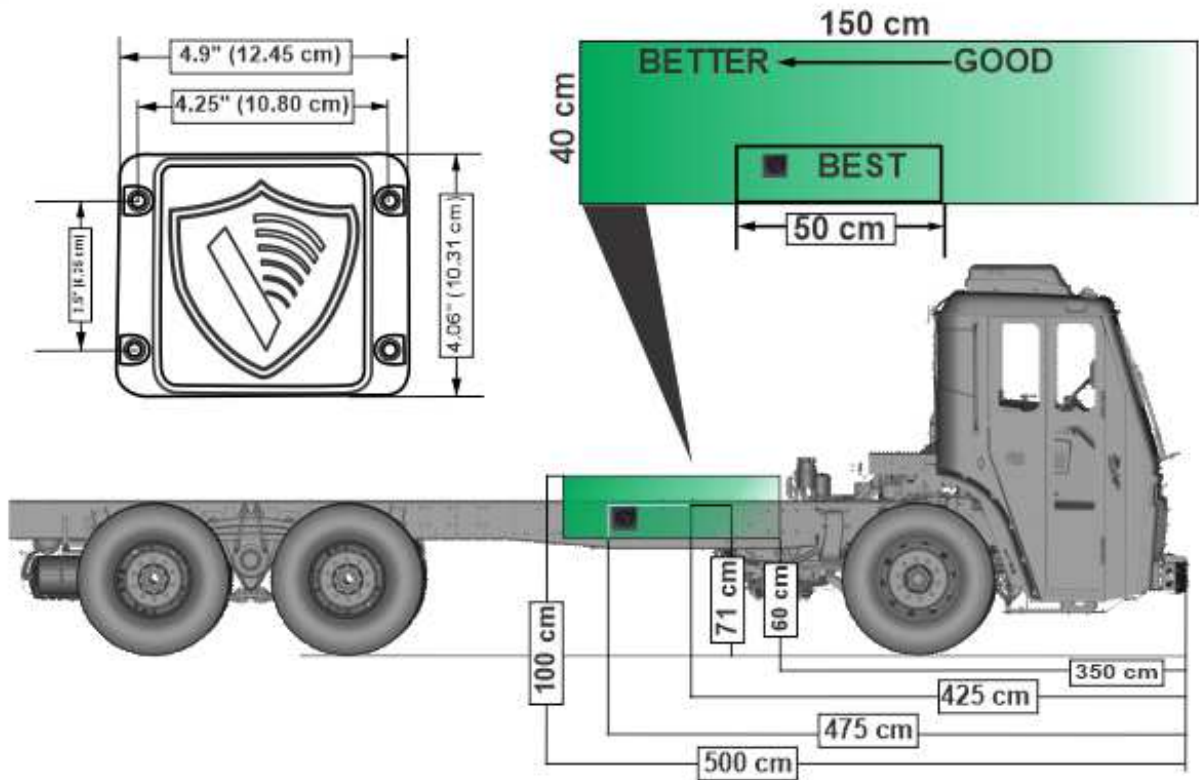

T3181888

Interference Zones (Side Defender II and Sentry Radar Sensor)

Metallic and other strong radar reflecting objects must remain outside of the Keep Out Zones. Radar reflecting objects within these areas may affect operation. If those objects cannot be removed, testing must be performed to determine the influence on the system's performance.

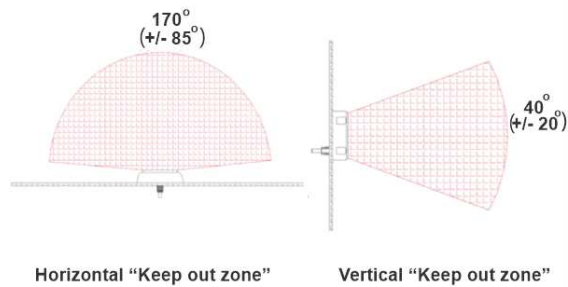

T3182126

Fig. 49 Keep out zones / Interference zones

FVSS, RWSS and MTCS Sensor Detection Zones

The FVSS has a wide horizontal field of view up to $150^{\circ}(\pm 75^{\circ})$ and with 5 zones of detection to giving the operator proximity to the object. The 5 proximity zones are equally divided from the detection zone length, i.e. 6 m (20') detection zone length, each zone equals 1.23 m (4').

The FVSS sensor has a 3 m (10') length X 3 m (10') Width detection zone. The RWSS sensor has a 6 m (20') length X 3 m (10') Width detection zone. The RWSS sensor is only active when the vehicle is in reverse mode and the FVSS sensor is only active when the vehicle is not in reverse.

The MTCS has a wide horizontal field of view up to $\pm 75^{\circ}$. The vertical field of view is $\pm 10^{\circ}$. The horizontal field-of-view is approximately 12 m along the vehicle side and extends approximately 3 m from the side of the vehicle. The detection zone for the MTCS when the vehicle is stationary; 5 m fore and 5 m aft of the sensor and 3 m out from the side of the vehicle. When in motion, the detection zone expands to 6 m fore and 6 m aft of the sensor out to 3 m from the side.

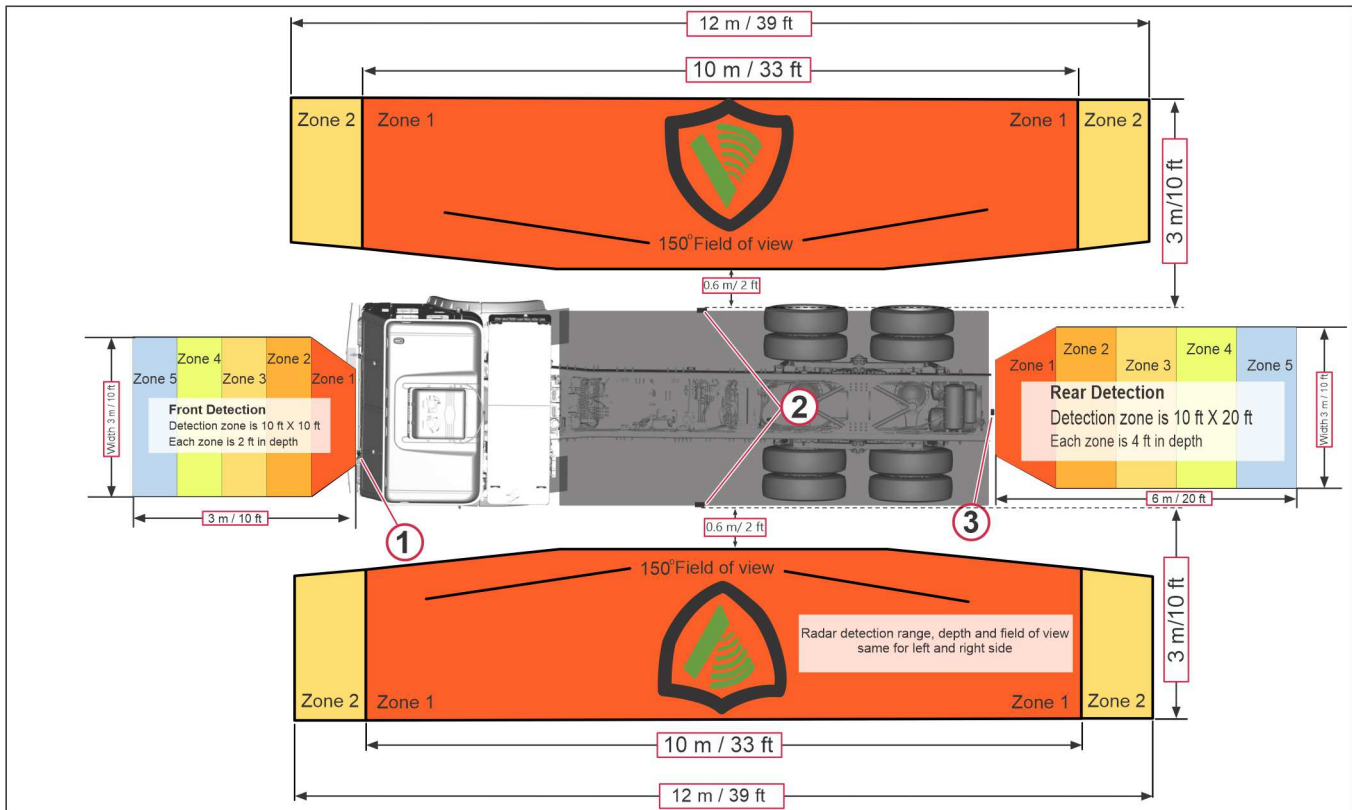

T3182127

- 1 Sensor, FVSS
- 2 Sensor, MTCS
- 3 Sensor, RWSS.

Note: The illustration represents the FVSS, RWSS and MTCS detection zone. The detection zone is an approximation that will vary depending on the detected object and operating conditions. For more information refer the operating manual.

Passive safety system Sensor Features

The sensor has Built-In-Self-Test (BIST) and blockage detection feature. BIST and blockage detection features are important to ensure the fail-safe operation of passive safety systems. The Built-In-Self-Test (BIST) feature notifies the driver about system failure through the in-cab LED display. This test functions by monitoring the transmit and receive performance as well as other internal operations. When the sensor face is obstructed by excessive ice, mud or snow, the Blockage detection feature determines and reports the driver through the in-cab LED display.

Type of connectors

The passive safety system uses the following types of connectors:

- 1 8-pin Deutsch connector pigtail (ST87 Series)
- 2 8-pin Conxall connector (ST82 Series).

Note: In the (ST87 Series) and (ST82 Series) the last digit indicates the type of connector (7– Deutsch connector, 2–Conxall connector).

Connector pin out

Note: The connector pin details are valid for FVSS , RWSS and MTCS. Sensor received with KIT and the sensors which are factory fitted in the vehicle may have any one of the connector.

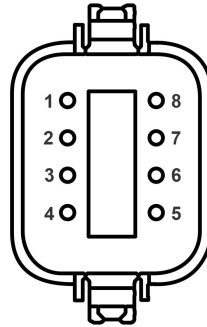

T3181879

Fig. 50 Deutsch Connector Pin Out

Connector Pin Out	
PIN	SIGNAL
1	Battery Power (+)
2	Ground
3	CAN High
4	CAN Low
5	Display Power (+)
6	Display Ground
7	N/C
8	Turn Signal Input

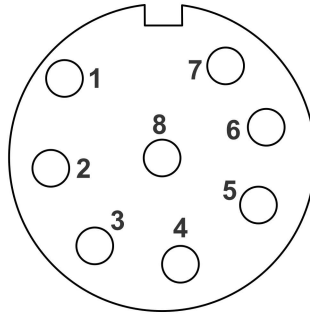

T3181878

Fig. 51 Conxall Connector Pin Out

Connector Pin Out	
PIN	SIGNAL
1	CAN High
2	CAN Low
3	Battery Power Input (+)
4	Ground
5	Display Power Output (+)
6	Display Ground
7	Auxiliary Out (Active Low)
8	Input

Wiring Diagram/ Preview System

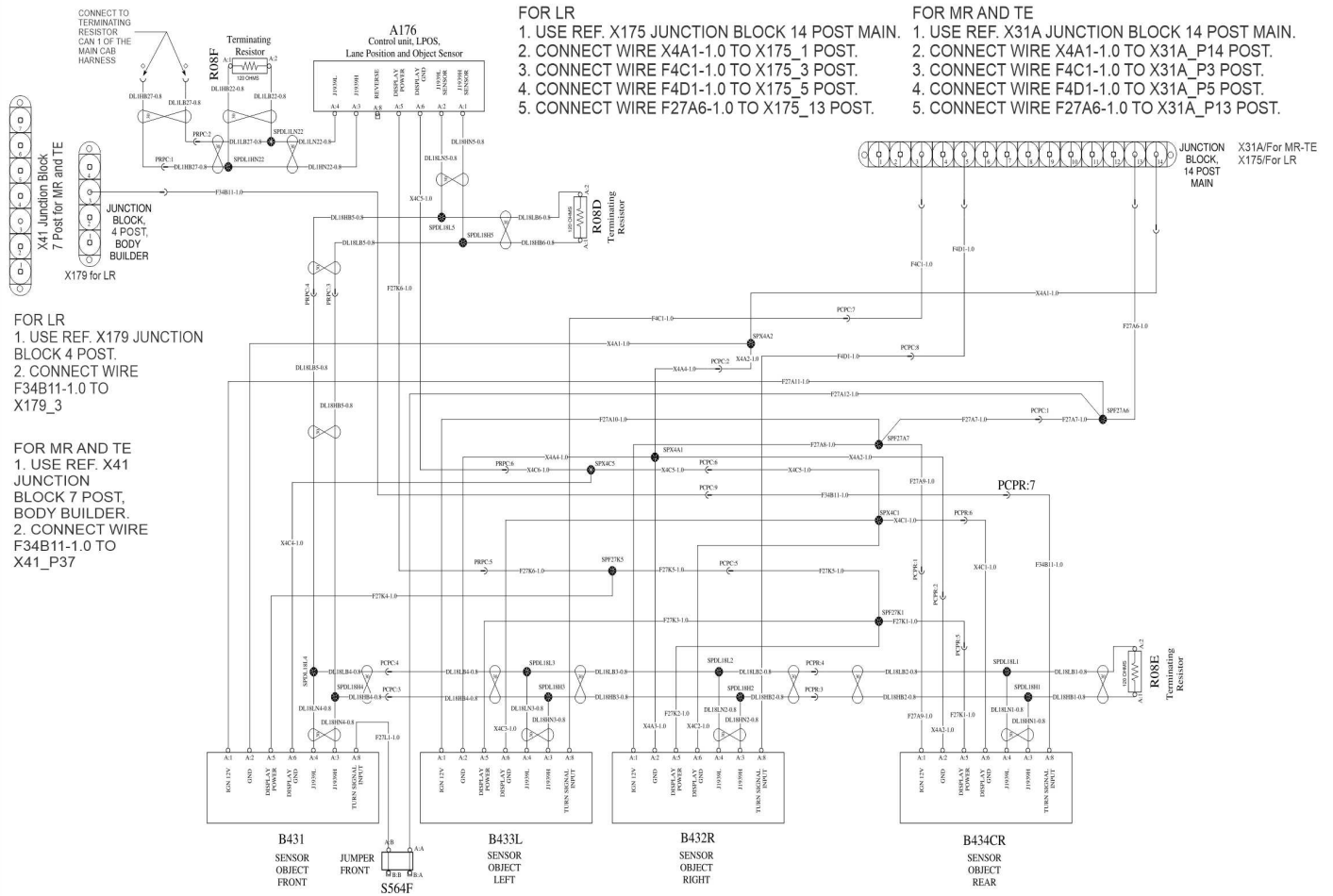

Component	Description
A176	Control unit, Lane position and object sensor (LPOS)
B431	Front object detection sensor i.e. FVSS
B432R	Right hand side objection detection sensor i.e. MTCS
B433L	Left hand side objection detection sensor i.e. MTCS
B434CR	Rearward object detection sensor i.e. RWSS
R08D	Terminating resistor
R08E	Terminating resistor
R08F	Terminating resistor
S564F	Jumper front
X31A	Junction block, 14 Post main
X41	Junction block, 7 Post, Body builder
X179	Junction Block, 4 post, Body Builder

Note: For more details refer the wiring diagram.

System Connection And Harness Routing

System connection

Locate the vehicle ignition power and connect to the red wire on the body harness. If it is necessary to extend the power wire on the supplied harness, use 20 American wire gauge (AWG) wires as a minimum. Locate the vehicle turn signal wire associated with the turn signal on the sensor side and connect it to the blue wire on the body harness. Connect the black wire of the body harness to the vehicle ground.



WARNING

Make sure that the turn signal wire you selected activates only when the turn signal is active. It should be operational signal.



WARNING

If the PreView Electronics® system is not wired properly, it may not operate as intended, which may result in a failure to warn the operator of a hazardous situation.

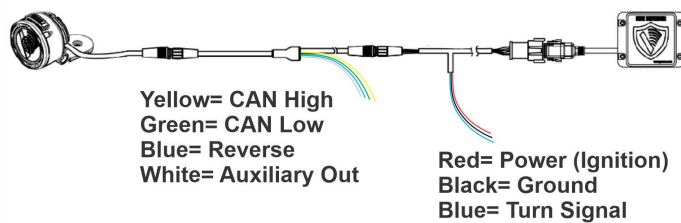

T3181917

Fig. 52 System connection

Harness Routing, Front View Support System (FVSS)

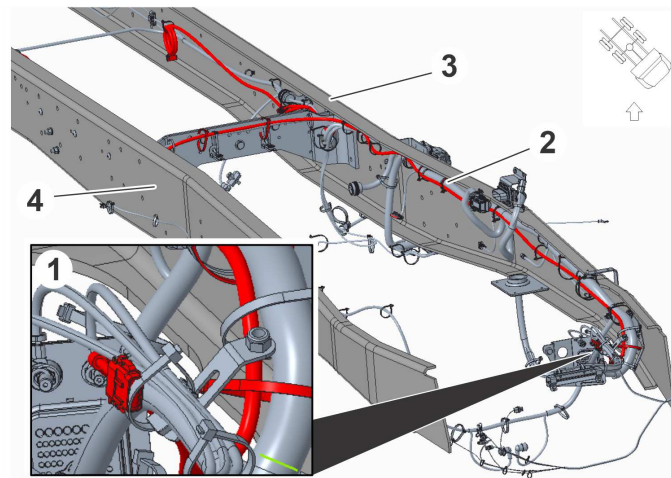

T3181914

Fig. 53 Harness Routing, FVSS

- 1 FVSS, Cab Connector
- 2 Chassis, Main Front Harness
- 3 Left Hand Side, Chassis Rail
- 4 Right Hand Side, Chassis Rail.

Harness Routing, Mitigate Turn Collision Support System (MTCS)

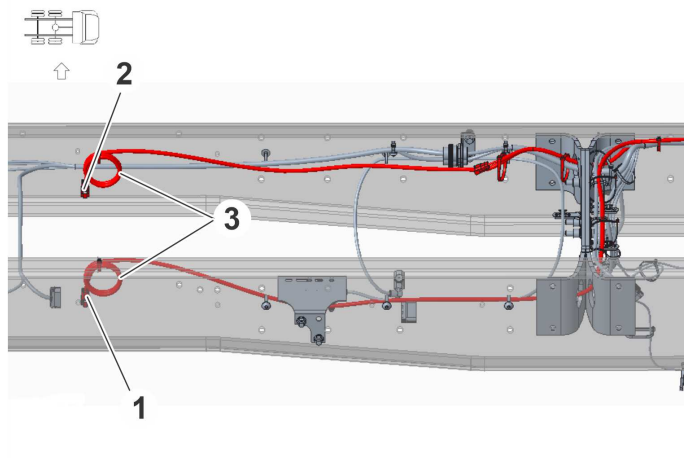

T3181915

Fig. 54 Harness Routing, MTCS

- 1 MTCS, Right Side Sensor
- 2 MTCS, Left Side Sensor
- 3 Extra Harness, Coiled Up.

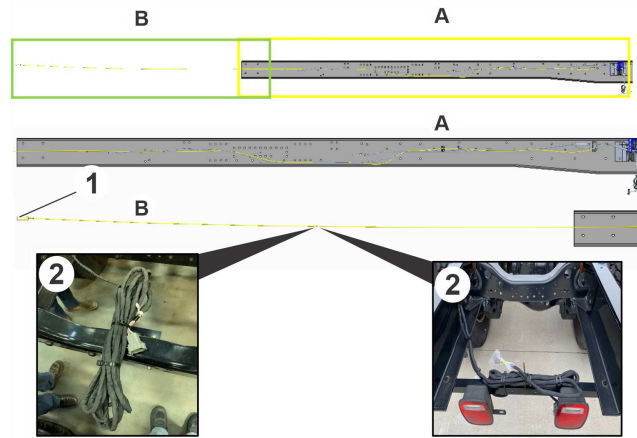

T3181916

Fig. 55 Harness Routing RWSS

- 1 RWSS, Connector
- 2 RWSS, Extra Harness, Coiled Up
- A- RWSS, Harness
- B- Extra Harness.

Passive Safety Support System Testing And Maintenance

Note: Although the sensor performs well in harsh environments (high temperature, fog, rain, snow, etc.), it is still recommended that the sensor face to be cleaned periodically.

Follow the below steps to check the functionality of the sensors;

- 1 Move the vehicle to an open field larger than the detection zone to test.
- 2 Keep the vehicle stationary.
- 3 Clean the sensor face if there is any accumulation of dirt, mud, snow, ice or debris.
- 4 Visually inspect the attached wiring and cable and ensure that they are properly secured.
- 5 Ensure that the wiring and cables are free from chafing, dangling, snagged or damage.
- 6 Clear all obstacles from the detection zone to avoid interference during the test.
- 7 Assistant walks a minimum speed of 5 km/h (3 mph) towards the sensor and the driver observes the alert activation point.
- 8 The assistant walks from the center of the sensor field straight back, away from the vehicle (the center line of the detection zone) and the driver observes the point at which alert stops.
- 9 The assistant moves to a point near the center of the detection zone and remains still for a few seconds. The warning continues, demonstrating the system ability to detect a still object.
- 10 The assistant moves a meter to the left of the sensor and walks towards the sensor again while the driver notes the alert.
- 11 Repeat the previous step moving out another meter to the left and walking towards the sensor again while the driver notes the alert.
- 12 Repeat this test sequence for the right-hand side.
- 13 Ensure that FVSS, MTCS and RWSS are providing the correct signal.

Note: Cover the complete detection zone of the FVSS, RWSS and MTCS sensor. Repeat the test as many times as necessary to ensure the sensor functionality.

Troubleshooting

1. Display Status LED is not illuminated

- Verify that DC power (9-33 V) is applied to the sensor
- Verify that the cabling between the sensor and display(s) is connected.

2. Display LED 2, 4 and 8, 10 are illuminated solid yellow

- The display is not receiving the vehicle speed message. Check the connection with the vehicle CAN-bus.

3. Detection LED are always illuminated when sensor is mounted

- Verify the sensor is pointing outward from the vehicle in an open area with no obstructions. This may require removing the mounting screws and lifting the sensor out away from the side of the vehicle. If the detection LED is not active when the sensor is moved away from the vehicle, but is active when mounted, then the sensor mounting position must be moved.



4. Detection buzzer sounds when turn signal is not active

- The harness turn signal wire is being set by other electronics, i.e., daytime running lights, air brakes, etc. Check turn signal wire connection.

5. Two display LED are flashing yellow and red

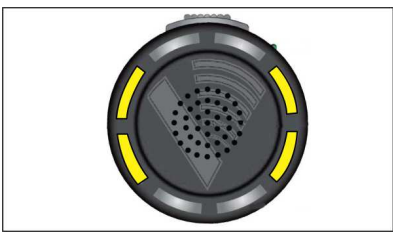
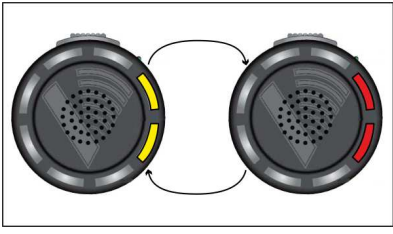
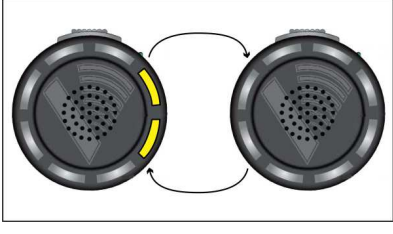
- A sensor located on the side (left, right, front or rear) indicated by the flashing LED is not communicating with the display. Check sensor to cable connection and ensure power is being provided to the sensor.

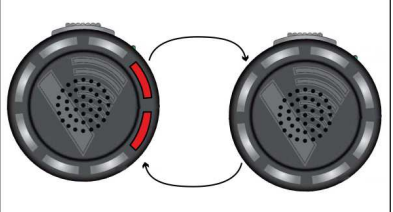
LED Alert	Problem	Description	Solution
 <p>T3182141</p>	No Speed Message		<p>D2002: Verify connection to vehicle CAN-Bus</p> <p>G2000: Verify GPS antenna connection and placement. Wait for GPS lock.</p>
 <p>T3182142</p>	Missing Sensor	The sensor on the side indicated is not communicating with display.	
 <p>T3182143</p>	Sensor Blockage	The sensor is blocked	Wipe the face of the sensor

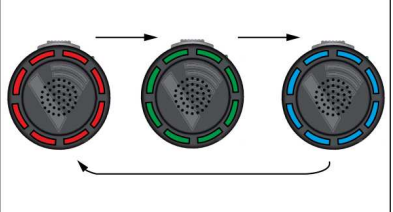
 <p>T3182144</p>	<p>Built-In Self Test Error</p>	<p>The sensor has failed the Built-In Self Test</p>	<p>Replace the sensor</p>
 <p>T3182145</p>	<p>Component Initialization Error</p>	<p>A component in the display has failed</p>	<p>Replace the display</p>
 <p>T3182146</p>	<p>LED Failure Error</p>	<p>One or more of the LEDs in the display have failed</p>	<p>Replace the display.</p>

Contact Sensata for PreView® Radar System Diagnostic, Support and/or Questions.

Email: previewsupport@sensata.com

Telephone: 844.787.2327

Website: www.sensata.com/products/blind-spot-monitoring-systems

Bendix® Wingman® Fusion™ 2.0 Advanced Driver Assistance System (Active safety system)

Bendix® Wingman® Fusion™ 2.0 Advanced Driver Assistance System brings together adaptive cruise control with braking features along with collision mitigation technology and Electronic Stability Program.

This Advanced Driver Assistance System (Active safety system) will help drivers during collisions, roll-over and loss-of-control situations.

Bendix® Wingman® Fusion™ 2.0 Driver Assistance System (Fusion) includes:

- 1 Bendix® Wingman® FLR21™ radar
- 2 Bendix™ AutoVue® FLC20™ Camera
- 3 Bendix® Driver Interface Unit (DIU™), or OEM dash display
- 4 Bendix® ESP® EC-80™ Controller

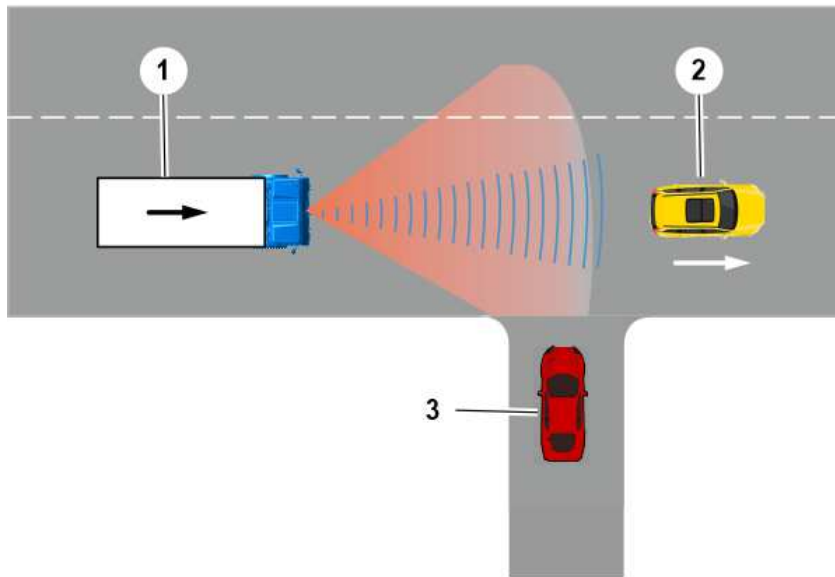

T3185733

1	Vehicle equipped with Bendix® Wingman® Fusion™ System
2	Detected Forward Vehicle
3	The System Does Not Brake nor Warn for Vehicles Approaching from the Side or Oncoming

FCM (Forward Collision Mitigation)

The FCM will help driver during forward collision of the vehicle.

The components of the FCM are:

- 1 FLR (Front Looking Radar)
- 2 FLC (Forward Looking Camera)
- 3 Driver Interface Unit (DIU™)

FLR (Front Looking Radar):

Radar (with a range of approximately 500 feet) mounted to the front of your vehicle, the System reacts ONLY to vehicles moving in the same direction as you. (The system DOES NOT respond to side-to-side moving traffic or oncoming traffic)

FLC (Forward Looking Camera):

The Bendix® Wingman® Fusion™ 2.0 camera (FLC) is mounted to the windshield of the vehicle. The camera will be mounted inside the wiper pattern and should be clear of any obstructions.

The Bendix® Wingman® Fusion™ 2.0 camera works with the radar to better identify forward vehicles (moving and stationary).

Driver Interface Unit (DIU™):

The DIU-FCM will be physically added to the cab interior to provide audible and visual indication of collision warnings and collision mitigation events.

ESP (Electronic Stability Program)

All vehicles equipped with the Bendix® Wingman® Fusion™ 2.0 system are also equipped with the Bendix® ESP® stability system. The Bendix® ESP stability system is an always ready, full-stability system which monitors vehicle performance. When necessary, Bendix® ESP automatically intervenes to reduce the throttle and/or apply the foundation brakes to help you maintain stability during potential loss-of-control or rollover events.

The Bendix® Wingman® Fusion™ 2.0 system uses the ESP system to help maintain vehicle stability during automatic brake applications on slick surfaces.

Components of ESP are:

- 1 ESP+ brake controller
- 2 Yaw rate sensor
- 3 Steering angle sensor

ESP+ brake controller:

The Bendix® ESP EC 80 Controller analyzes the vehicle's motion compared to the driver's intended path and provides Yaw Control (YC) and Roll Stability Program (RSP) capabilities. When necessary, the system will intervene to reduce the engine throttle, and/or apply the brakes at one or more of the wheel ends – to help the vehicle return to the intended direction.

Yaw rate sensor:

Yaw control helps reduce understeer and oversteer conditions in situations with low or medium friction coefficients between the tires and road surface.

Steering angle sensor:

Bendix® Wingman® Fusion™ 2.0 brand Steering Angle Sensors (SAS) are used to report the steering wheel position to the Controller, utilizing a dedicated serial communications link that is shared with the Yaw Rate Sensor.

Component location

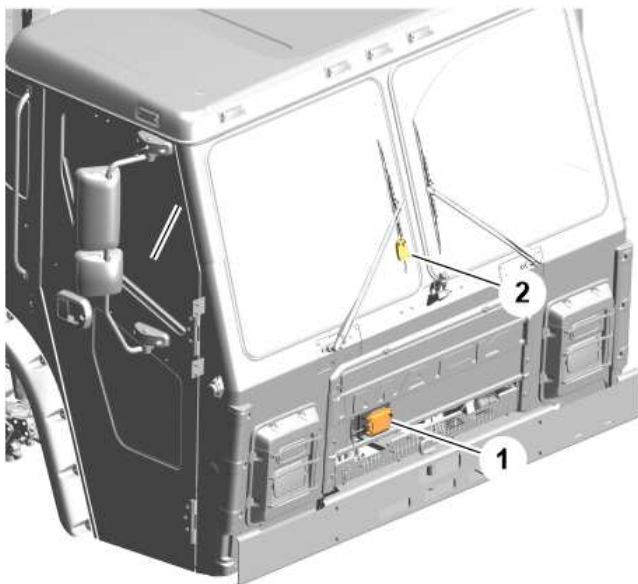

T3184739

1	FLR-FCM (Forward Looking Radar- Forward Collision Mitigation)
2	FLC (Forward Looking Camera)

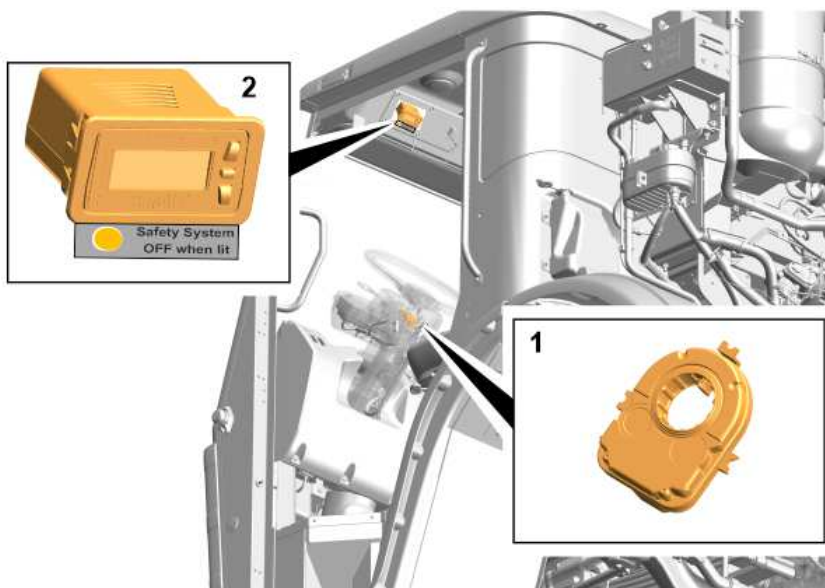

T3184741

1	Steering Angle Sensor
2	Bendix® Wingman® Fusion™ 2.0 DIU (Driver Interface Unit)

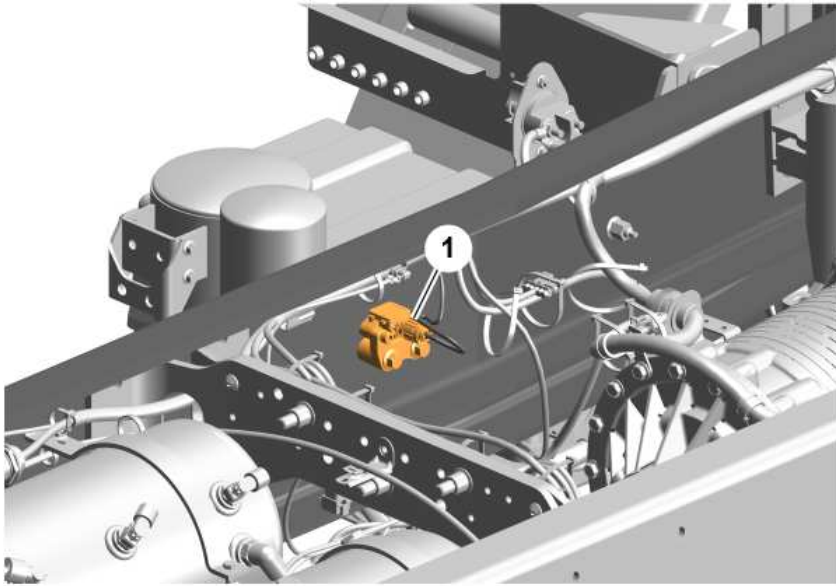

T3184740

1	Yaw Rate Sensor
---	-----------------

Snow plow/Curotto Cans

It is possible to enable/disable the FLR (Forward Looking Radar) and FVSS (Forward View Support System) to accommodate a "SNOW PLOW"/"Curotto cans" before engine start. FLR and FVSS are blocked when the snow plow/curotto Cans is attached to the vehicle. When snow plow/curotto Cans is in use, an amber light illuminates to indicate that the Bendix® Wingman® Fusion™ 2.0 is disabled.

Note: For more detail about FVSS (Forward View Support System) sensor refer "Sensata Technologies PreView System" section.

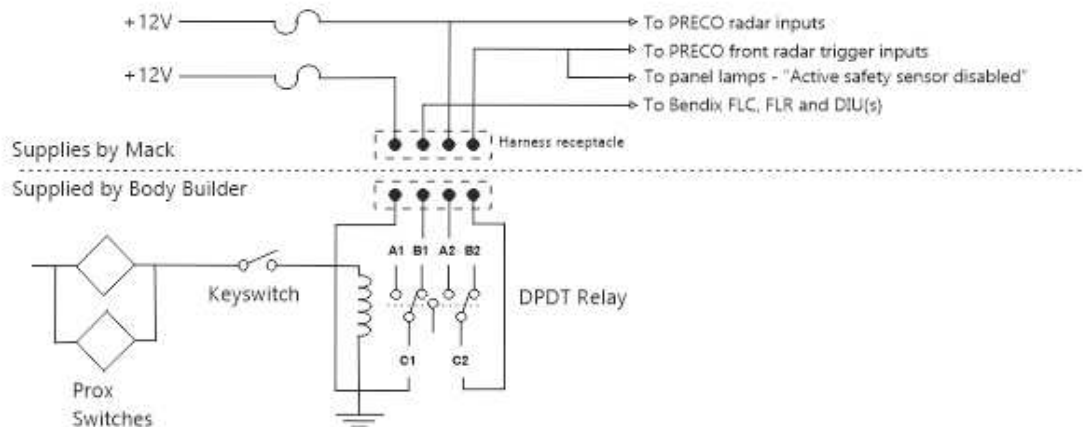

T3185095

Snow Plow/Curotto Can Disable Interface

A combination of proximity switches and keyswitch can be used to control a switching relay.

When the relay is de-energized, the circuit path B1-C1 is closed and the FCM system remains active. When the relay is energized, the circuit path B1-C1 is open and the FCM system is disabled.

When the relay is de-energized, the circuit path A2-C2 is open and the front BSM (Blind Spot Monitoring) radar remains active. Then the relay is energized, the circuit path A2-C2 is closed and the front BSM radar is disabled.

Location for Snow plow/Curotto Cans connector

For MR,

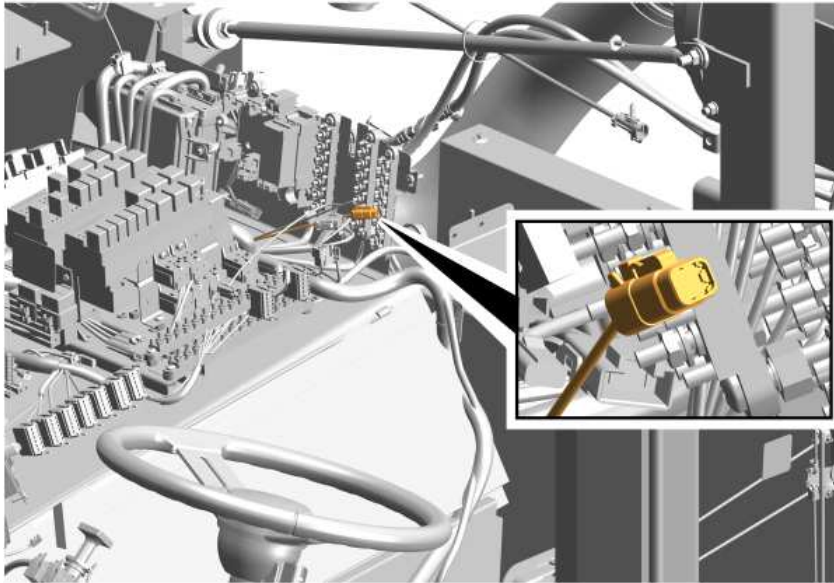

T3184742

For LR,

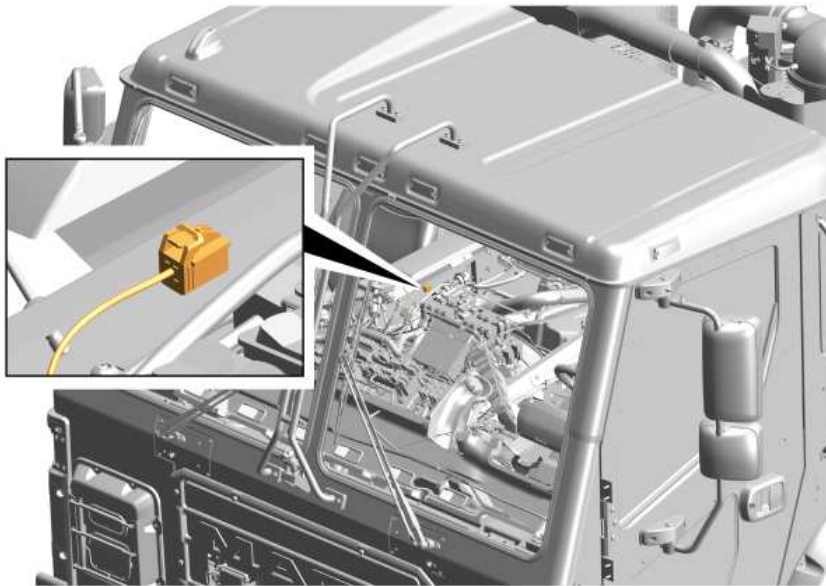

T3184743

Mating connector part number is 21138416 and terminal part number is 993718.

Liftgate trailer connector usage recommendations

Scope

This section outlines the safety aspects concerning the interface between the trailer connector installed in the vehicle and the bodybuilder equipment.

The trailer connector is located in the truck, either at the back of the cab or at the end of the frame.

The truck side harness and components can handle a maximum of 150A without any issues before the circuit breaker trips.

Recommendations

- The trailer side harness should be sized to be compatible with the truck side harness; the truck harness is, by default, a 2GA cable.
- The truck offers a ground strap from the fifth wheel. This should be connected to the trailer frame to create a consistent ground path, which can prevent short circuits.
- Proper maintenance of the cables and connectors on the trailer side should be ensured to prevent corrosion, thereby reducing the risk of intermittent short circuits.

Note: The location of trailer connection receptacle may vary based on the truck variant, either at back of cab or at the end of frame.

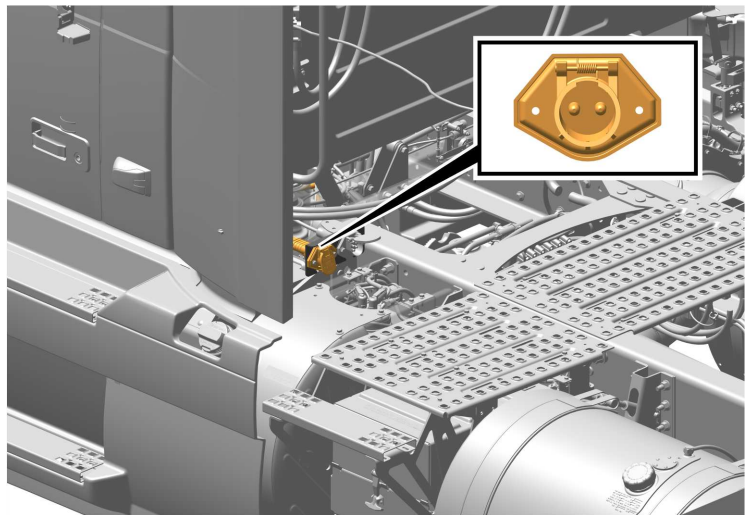

T3202040



WARNING

This trailer connector is intended solely for use with the Lift gate and charging the trailer batteries. Usage for other power supply purposes, such as refrigeration, is strictly prohibited, as the wires are not designed to handle high loads.